

# Power Take-Offs Parts List

281, 288 Series



### **WARNING – User Responsibility**

FAILURE OR IMPROPER SELECTION OR IMPROPER USE OF THE PRODUCTS DESCRIBED HEREIN OR RELATED ITEMS CAN CAUSE DEATH, PERSONAL INJURY AND PROPERTY DAMAGE.

This document and other information from Parker Hannifin Corporation, its subsidiaries and authorized distributors provide product or system options for further investigation by users having technical expertise.

The user, through its own analysis and testing, is solely responsible for making the final selection of the system and components and assuring that all performance, endurance, maintenance, safety and warning requirements of the application are met. The user must analyze all aspects of the application, follow applicable industry standards, and follow the information concerning the product in the current product catalog and in any other materials provided from Parker or its subsidiaries or authorized distributors.

To the extent that Parker or its subsidiaries or authorized distributors provide component or system options based upon data or specifications provided by the user, the user is responsible for determining that such data and specifications are suitable and sufficient for all applications and reasonably foreseeable uses of the components or systems.

### **Offer of Sale**

The items described in this document are hereby offered for sale by Parker Hannifin Corporation, its subsidiaries or its authorized distributors. This offer and its acceptance are governed by the provisions stated in the "Offer of Sale".

© Copyright 2023, Parker Hannifin Corporation, All Rights Reserved

**Table of Contents**

---

**281 Series**

Model Number Designator.....1

Exploded View.....2

Bill of Materials ..... 3-5

Gear Ratio Options.....6

Lube Options..... 7-9

Shift Options.....10

Assembly Arrangements.....11

Output Options..... 12-21

Installation Sketches ..... 22-29

**288 Series**

Model Number Designator.....31

Exploded View.....32

Bill of Materials ..... 33-34

Gear Ratio Options.....35

Lube Options..... 36-37

Assembly Arrangements.....38

Output Options..... 39-42

Installation Sketches .....43

Kits Bill of Materials..... 44-53

Offer of Sale ..... 55-57





**Model Number Designator**

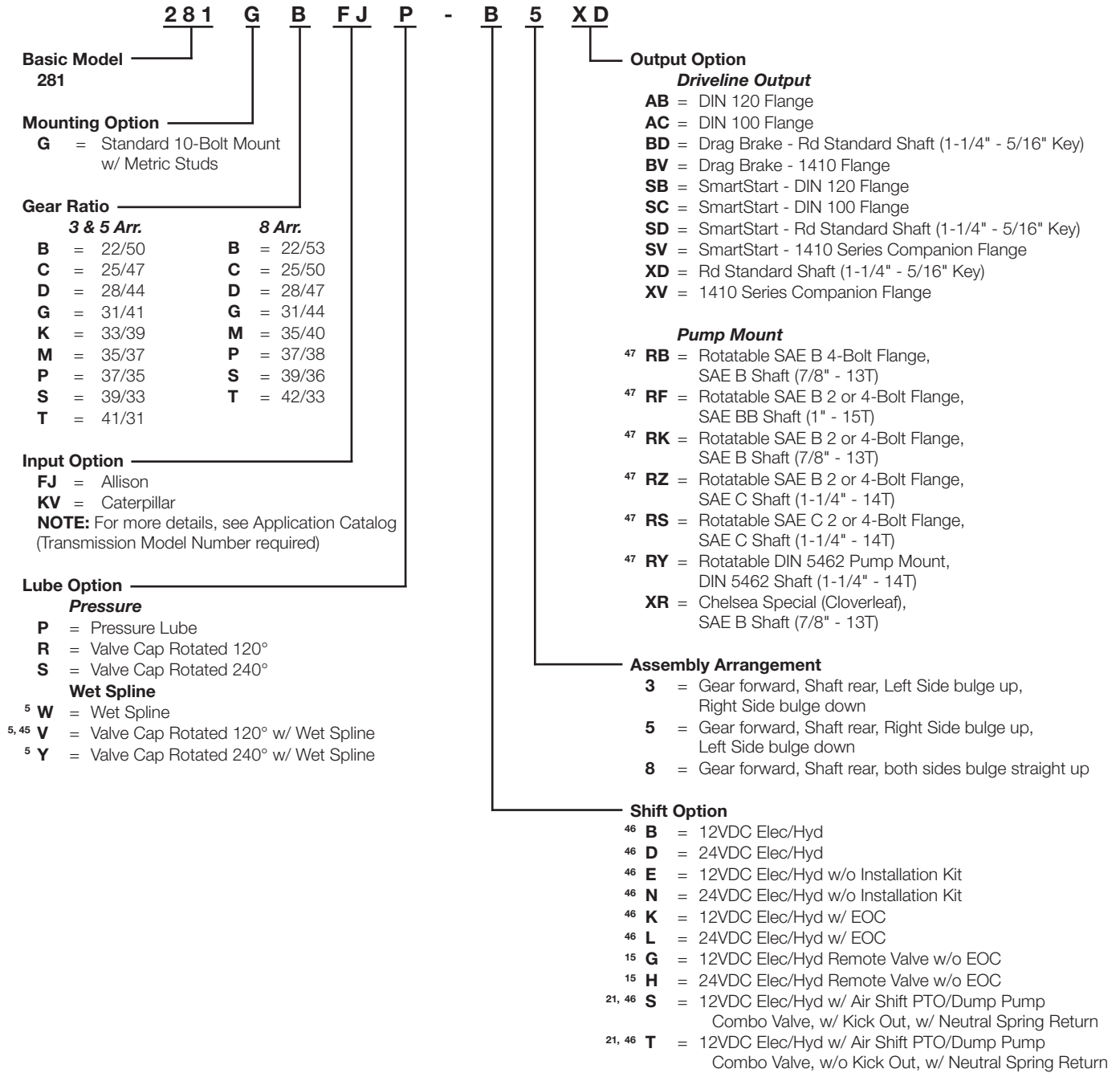

<sup>5</sup> Automatically Pressure Lubed

<sup>15</sup> The remote mount solenoid option can not utilize the EOC option.

<sup>21</sup> Includes Installation Kit, Console Sold Separately.

<sup>45</sup> Available on Shift Option B, D, K, L, E, N, S & T.

<sup>46</sup> Available with Rotated Valve

<sup>47</sup> Available with Wet Spline

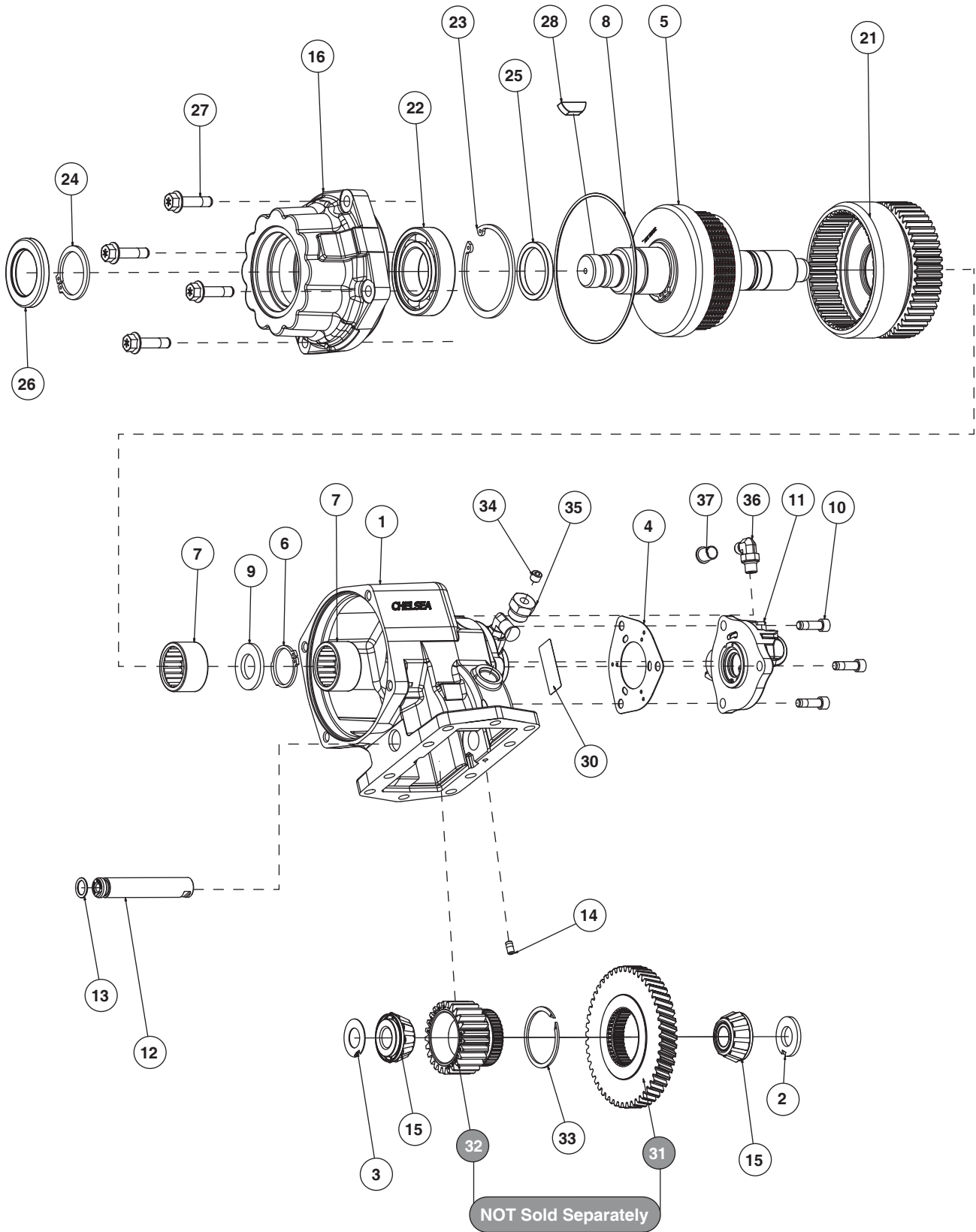

**Bill of Materials**

Item	Part Number	Description	Qty.
1	<b>1-P-813</b>	Housing (3 Arrangement with O-ring).....	1 or
	<b>1-P-814</b>	Housing (5 Arrangement with O-ring).....	1 or
	<b>1-P-815</b>	Housing (8 Arrangement with O-ring).....	1
2	<b>14-P-73-1</b>	Spacer (.762" x 1.500" x .150") (Thickness as Required).....	1
	<b>14-P-73-2</b>	Spacer (.762" x 1.500" x .153").....	1
	<b>14-P-73-3</b>	Spacer (.762" x 1.500" x .156").....	1
3	<b>31-P-102</b>	Thrust Washer (.754" x .440" x .030").....	1
4	<b>22-P-112</b>	Valve Cap Gasket.....	1
5	<b>330155-6X</b>	Drive Shaft & Clutch Assembly (XD).....	1 or
	<b>330155-9X</b>	Drive Shaft & Clutch Assembly w/ SmartStart (SD).....	1
6	<b>379746</b>	Lockring.....	1
7	<b>560972</b>	Bearing Needle Roller Assembly (1.500" x 1.875" x 1.000").....	2
8	<b>28-P-329</b>	O-ring (5.487" x .103").....	1
9	<b>31-P-70</b>	Thrust Washer (1.507" x 2.167" x .094").....	1
10	<b>378447-6</b>	Socket Head Cap Screw (.312"-18 x 1.000").....	3
11	<b>329463-12X</b>	12VDC Valve Cap Assembly (FJ Input Option).....	1 or
	<b>329463-24X</b>	24VDC Valve Cap Assembly (FJ Input Option).....	1
	<b>329442-12X</b>	12VDC Valve Cap Assembly (KV Input Option).....	1 or
	<b>329442-24X</b>	24VDC Valve Cap Assembly (KV Input Option).....	1
	<b>329403X</b>	Remote Valve Cap Assembly.....	1 or
12	<b>9-P-106</b>	Idler Shaft (.750").....	1
13	<b>28-P-191</b>	O-ring (.549" x .103").....	1
14	<b>378452-7</b>	Socket Head Set Screw (.250"-20 x .500").....	1
15	<b>550439</b>	Bearing Tapered Cone (.750" x .598").....	2 or
	<b>561006</b>	Bearing Tapered Cone (.750" x .655") (B Ratio Only).....	2
16	<b>21-P-932</b>	Bearing Cap (SD, XD, XV, SV Only).....	1 or
	<a href="#">See pages 12-21</a>	Output Options (All Other Outputs).....	1
21	<a href="#">See page 6</a>	Output Gear.....	1
22	<b>550311</b>	Ball Bearing (1.770" x 3.346" x .748").....	1
23	<b>378263</b>	Internal Lockring.....	1
24	<b>379555</b>	Lockring.....	1
25	<b>4-P-187</b>	Spacer (1.776" x 2.200" x .239").....	1
26	<b>28-P-267</b>	Oil Seal (2.627" x 1.750" x .312").....	1
27	<b>380563-14</b>	Hex Flange Head Cap Screw (.375"-16 x 1.500") (w/ 3/8" Bearing Cap Bolts).....	4
28	<b>500007-29</b>	Woodruff Key (SD & XD Output Only).....	1
30	<b>68-P-51-1</b>	Adhesive Label.....	1
<b>Not Sold Separately</b>			
31	<a href="#">See page 6</a>	Input Gear.....	1
32	<a href="#">See page 6</a>	Ratio Gear.....	1
33	<b>379522</b>	Lockring.....	1
34	<b>379231</b>	Pipe Plug (.125"-27) (w/o EOC Only).....	1
35	<b>379242</b>	Straight Adapter (.125"-27 x .750"-16) (w/o ECO Only).....	1

Continued on Next Page

**Bill of Materials**

Item	Part Number	Description	Qty.
36	379486	90° Elbow (.438"-20) .....	1
37	379564-2	Thread Cap (.438") .....	1
38	379243	Speed Sensor (w/ EOC Only).....	1
39	28-P-171	O-ring (.644" x .087") (w/ EOC Only).....	1
<p><b>See pages 44-53 for Bill of Materials for the below loose parts.</b></p>			
<p><b>SERVICE KITS</b></p>			
	329071-64X	Bearing Kit (BV)	
	329071-63X	Bearing Kit (AC, XD, XV, RF, RK, RS, RY, RZ)	
	329071-80X	Gasket & Seal Kit	
	329071-82X	Gasket & Seal Kit (BV)	
	330154X	Gear & Clutch Plates Kit (7-8 Clutch Pack)	
	329071-83X	Hydraulic Valve O-ring Kit (BD, BV)	
<p><b>STUD KITS</b></p>			
	7170-86X	Mounting Kit (FJ Input Option, 3 & 5 Arrangement) .....	1 or
	7170-107X	Mounting Kit (FJ Input Option, 8 Arrangement) .....	1 or
	7170-117X	Mounting Kit (KV Input Option, 3 & 5 Arrangement) .....	1 or
	7170-118X	Mounting Kit (KV Input Option, 8 Arrangement) .....	1
<p><b>INSTALLATION INSTRUCTION KIT</b></p>			
	328948-9X	Gasket & Installation Instructions Kit .....	1
<p><b>HYDRAULIC INSTALLATION KITS</b></p>			
	329024-12X	12VDC Installation Kit (FJ Input Option, B Shift)	
	329024-24X	24VDC Installation Kit (FJ Input Option, D Shift)	
	329076X	12VDC & 24VDC w/ EOC Installation Kit (FJ Input Option, K & L Shift)	
	329237-12X	12VDC Remote Valve w/o EOC Installation Kit (FJ Input Option, G Shift)	
	329237-24X	24VDC Remote Valve w/o EOC Installation Kit (FJ Input Option, H Shift)	
	329443-12X	12VDC Installation Kit (KV Input Option, B Shift)	
	329443-24X	24VDC Installation Kit (KV Input Option, D Shift)	
	329444X	12VDC & 24VDC w/ EOC Installation Kit (KV Input Option, K & L Shift)	
	329445-12X	12VDC Remote Valve w/o EOC Installation Kit (KV Input Option, G Shift)	
	329445-24X	24VDC Remote Valve w/o EOC Installation Kit (KV Input Option, H Shift)	
	329650X	Electronic Overspeed Controls (K & L Shift)	

Continued on Next Page

**Bill of Materials**

Item	Part Number	Description	Qty.
		<b>AIR INSTALLATION KITS</b>	
	<b>328388-85X</b>	Air Shift Installation Kit (S Shift)	
	<b>328388-86X</b>	Air Shift Installation Kit (T Shift)	
		<b>SHIFTER CONVERSION KITS</b>	
	<b>329175-12X</b>	12VDC EOC Conversion Kit (FJ Input Option)	
	<b>329175-24X</b>	24VDC EOC Conversion Kit (FJ Input Option)	
	<b>329354-12X</b>	12VDC Remote Valve Conversion Kit (All)	
	<b>329354-24X</b>	24VDC Remote Valve Conversion Kit (All)	
	<b>329448-12X</b>	12VDC EOC Conversion Kit (KV Input Option)	
	<b>329448-24X</b>	24VDC EOC Conversion Kit (KV Input Option)	
		<b>HOSE ASSEMBLIES</b>	
	<b>329057-3X</b>	Lube Hose Assembly (G & H Shift) .....	1
	<b>329057-4X</b>	Lube & Clutch Hose Assembly (G & H Shift) .....	1
	<b>328075X</b>	Exhaust Hose Assembly (G & H Shift) .....	1
	<b>329075-5X</b>	Pressure Hose Assembly (KV Input Option)	
	<b>329141-1X</b>	Pressure Hose Assembly (FJ Input Option)	
		<b>OUTPUT CONVERSION KITS</b>	
	<a href="#">See page 49</a>	Output Conversion Kits Bill of materials	

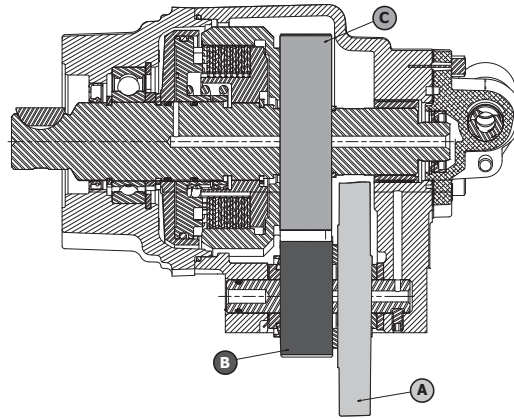

**3 and 5 Assembly**

GEAR DESIGNATOR	INPUT GEAR ASSEMBLY	NOT Sold Separately				OUTPUT GEAR (21)	NO. TEETH C
		INPUT GEAR (31)	NO. TEETH A	RATIO GEAR (32)	NO. TEETH B		
281*BFJ	5-P-1491-1X	5-P-1491	50	5-P-1478	22	2-P-926	50
281*CFJ	5-P-1491-2X	5-P-1491	50	5-P-1495	25	2-P-927	47
281*DFJ	5-P-1491-3X	5-P-1491	50	5-P-1479	28	2-P-928	44
281*GFJ	5-P-1491-4X	5-P-1491	50	5-P-1480	31	2-P-929	41
281*KFJ	5-P-1491-5X	5-P-1491	50	5-P-1481	33	2-P-931	39
281*MFJ	5-P-1491-6X	5-P-1491	50	5-P-1482	35	2-P-933	37
281*PFJ	5-P-1491-7X	5-P-1491	50	5-P-1483	37	2-P-935	35
281*SFJ	5-P-1491-8X	5-P-1491	50	5-P-1484	39	2-P-936	33
281*TFJ	5-P-1491-9X	5-P-1491	50	5-P-1497	41	2-P-937	31
281*BKV	5-P-1493-1X	5-P-1493	45	5-P-1478	22	2-P-926	50
281*CKV	5-P-1493-2X	5-P-1493	45	5-P-1495	25	2-P-927	47
281*DKV	5-P-1493-3X	5-P-1493	45	5-P-1479	28	2-P-928	44
281*GKV	5-P-1493-4X	5-P-1493	45	5-P-1480	31	2-P-929	41
281*KKV	5-P-1493-5X	5-P-1493	45	5-P-1481	33	2-P-931	39
281*MKV	5-P-1493-6X	5-P-1493	45	5-P-1482	35	2-P-933	37
281*PKV	5-P-1493-7X	5-P-1493	45	5-P-1483	37	2-P-935	35
281*SKV	5-P-1493-8X	5-P-1493	45	5-P-1484	39	2-P-936	33
281*TKV	5-P-1493-9X	5-P-1493	45	5-P-1497	41	2-P-937	31

**8 Assembly**

GEAR DESIGNATOR	INPUT GEAR ASSEMBLY	NOT Sold Separately				OUTPUT GEAR (21)	NO. TEETH C
		INPUT GEAR (31)	NO. TEETH A	RATIO GEAR (32)	NO. TEETH B		
281*BFJ	5-P-1491-1X	5-P-1491	50	5-P-1478	22	2-P-925	53
281*CFJ	5-P-1491-2X	5-P-1491	50	5-P-1495	25	2-P-926	50
281*DFJ	5-P-1491-3X	5-P-1491	50	5-P-1479	28	2-P-927	47
281*GFJ	5-P-1491-4X	5-P-1491	50	5-P-1480	31	2-P-928	44
281*MFJ	5-P-1491-6X	5-P-1491	50	5-P-1482	35	2-P-930	40
281*PFJ	5-P-1491-7X	5-P-1491	50	5-P-1483	37	2-P-932	38
281*SFJ	5-P-1491-8X	5-P-1491	50	5-P-1484	39	2-P-934	36
281*TFJ	5-P-1491-10X	5-P-1491	50	5-P-1485	42	2-P-936	33
281*BKV	5-P-1493-1X	5-P-1493	45	5-P-1478	22	2-P-925	53
281*CKV	5-P-1493-2X	5-P-1493	45	5-P-1495	25	2-P-926	50
281*DKV	5-P-1493-3X	5-P-1493	45	5-P-1479	28	2-P-927	47
281*GKV	5-P-1493-4X	5-P-1493	45	5-P-1480	31	2-P-928	44
281*MKV	5-P-1493-6X	5-P-1493	45	5-P-1482	35	2-P-930	40
281*PKV	5-P-1493-7X	5-P-1493	45	5-P-1483	37	2-P-932	38
281*SKV	5-P-1493-8X	5-P-1493	45	5-P-1484	39	2-P-934	36
281*TKV	5-P-1493-10X	5-P-1493	45	5-P-1485	42	2-P-936	33

**Integral Solenoid Valve**

**Pressure Lube (P)  
 or Wet Spine (W)**

**3 Arrangement**

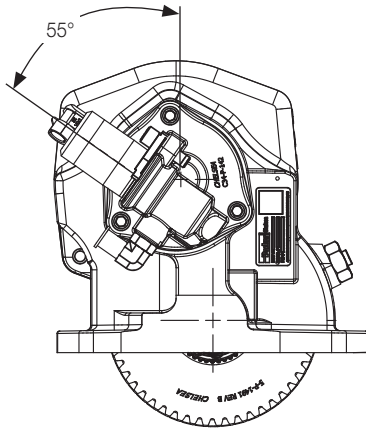

**5 Arrangement**

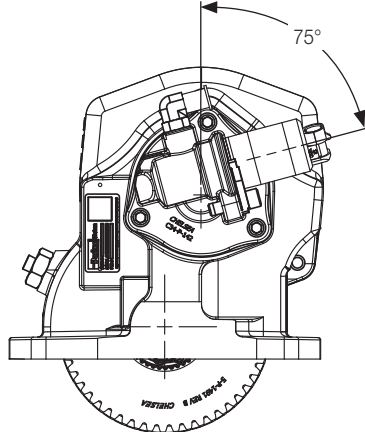

**8 Arrangement**

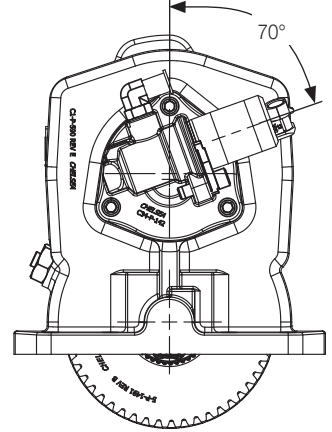

**Valve Cap Rotated 120° (R)  
 or Wet Spine (V)**

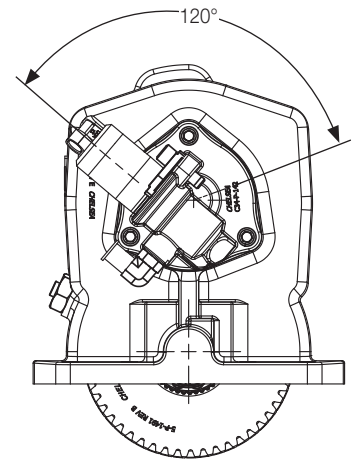
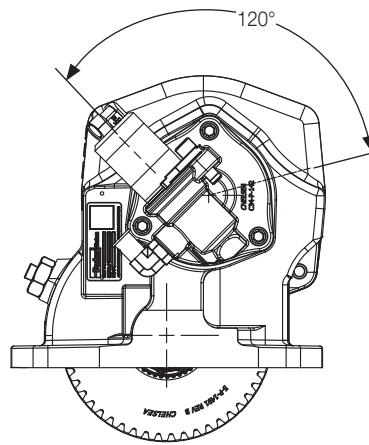
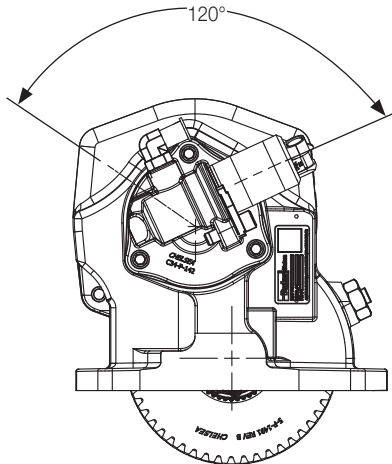

**Valve Cap Rotated 240° (S)  
 or Wet Spine (Y)**

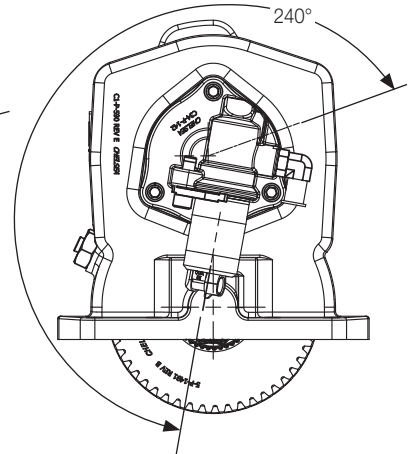
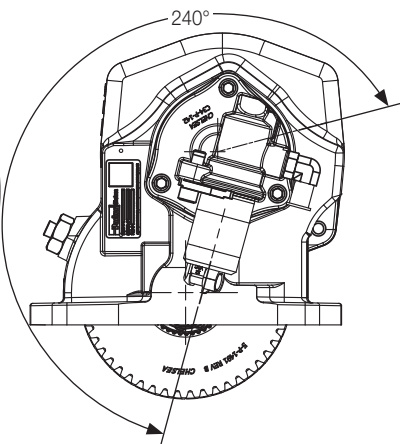
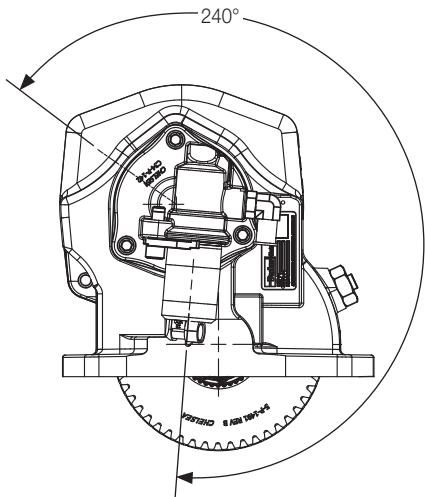



Lube Options

Remote Solenoid Valve

Pressure Lube (P)  
or Wet Spline (W)

3 Arrangement

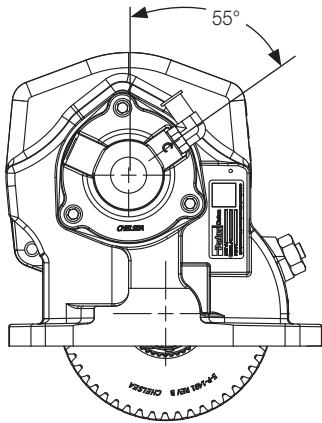

5 Arrangement

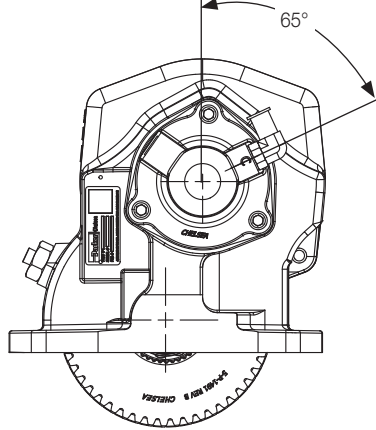

8 Arrangement

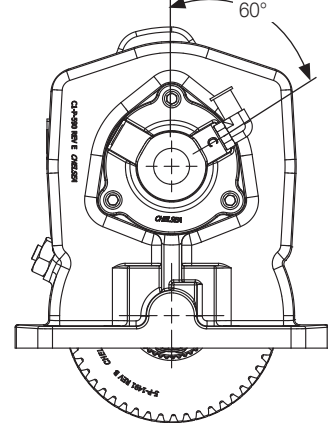

Valve Cap Rotated 120° (R)  
or Wet Spline (V)

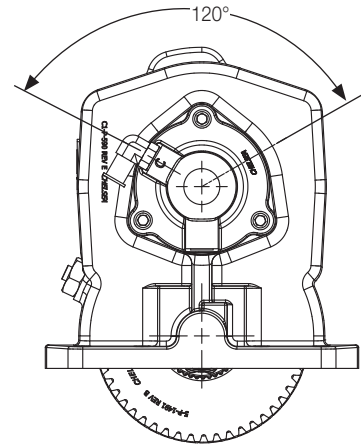
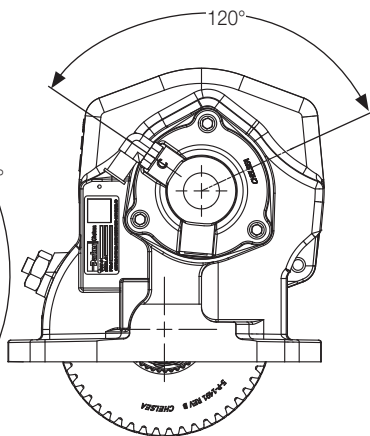
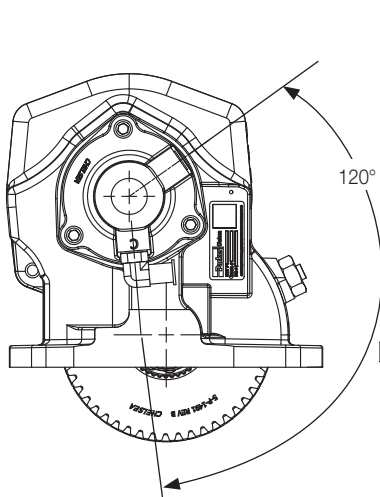

Valve Cap Rotated 240° (S)  
or Wet Spline (Y)

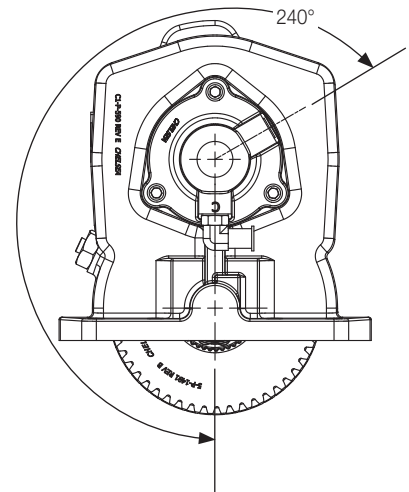
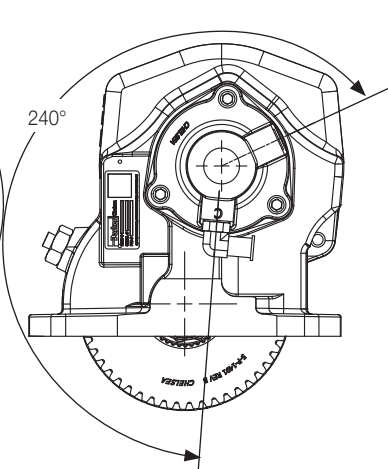
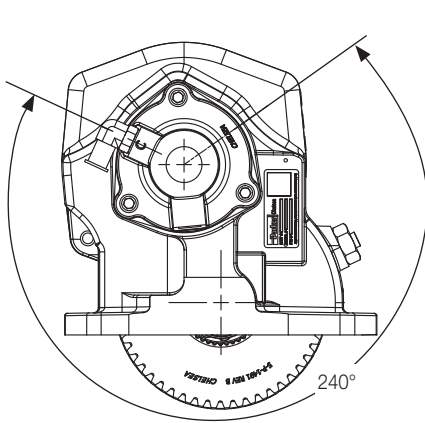



**Pressure Lube**

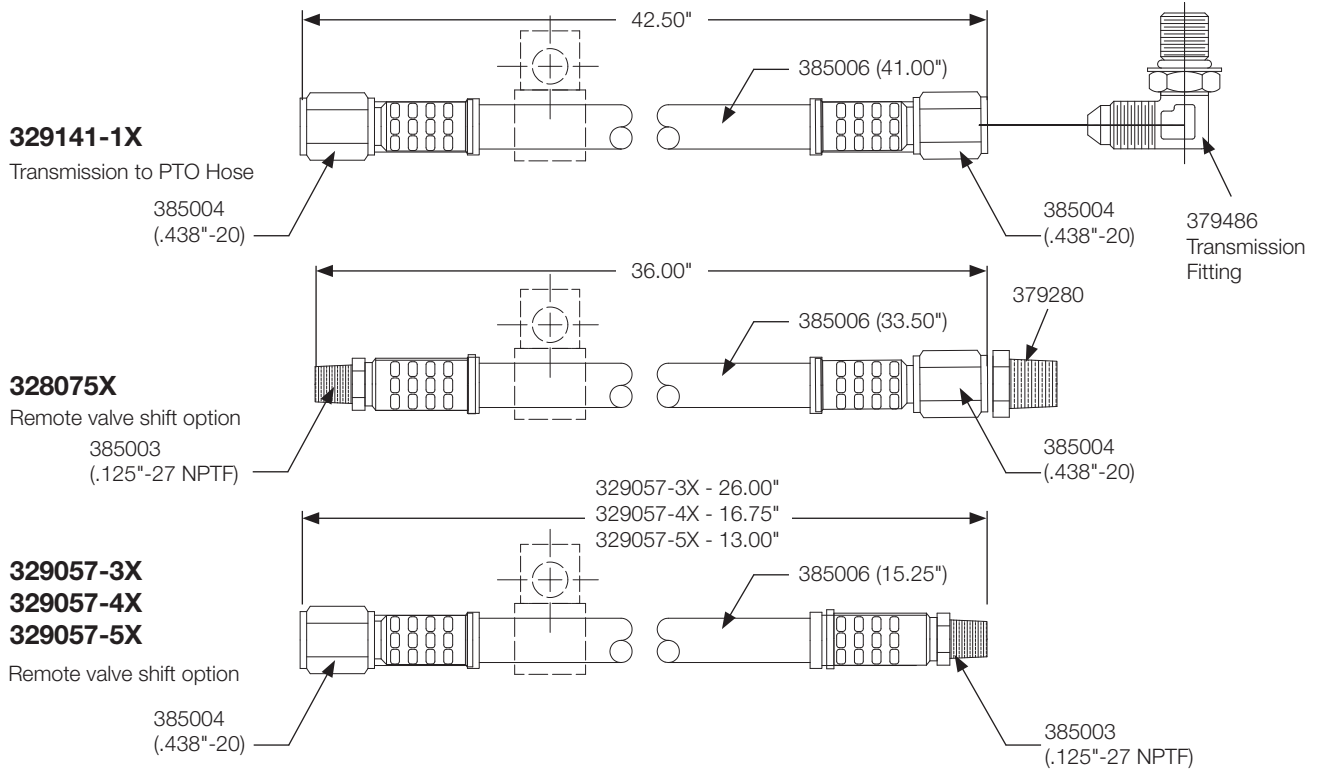

**Wet Spline Installation RB, RF, RK, RS, RY & RZ Output Options**

**(SK-508 Rev C)**

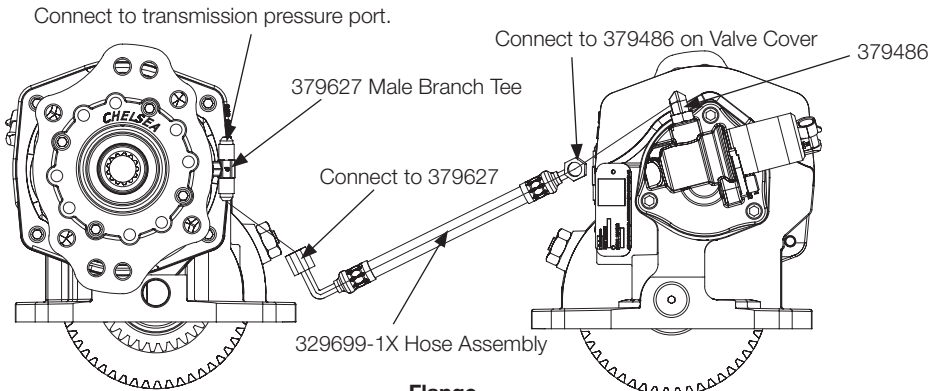

Wet Spline Installation Kits	
Output	Kit Number
RB	329959X
RK	329700X
RF	329700X
RS	329744X
RY	329742X
RZ	329700X

**NOTE:** Not all output options may be available on Series listed above

- Flange**
- RB 21-P-894
  - RF/RK/RZ 21-P-731
  - RS 21-P-769
  - RY 21-P-771
- 35-P-101 Gasket

- Wet Spline Gasket or O-ring**
- RB 35-P-104
  - RF/RK/RZ 35-P-102
  - RS 28-P-245
  - RY 35-P-111

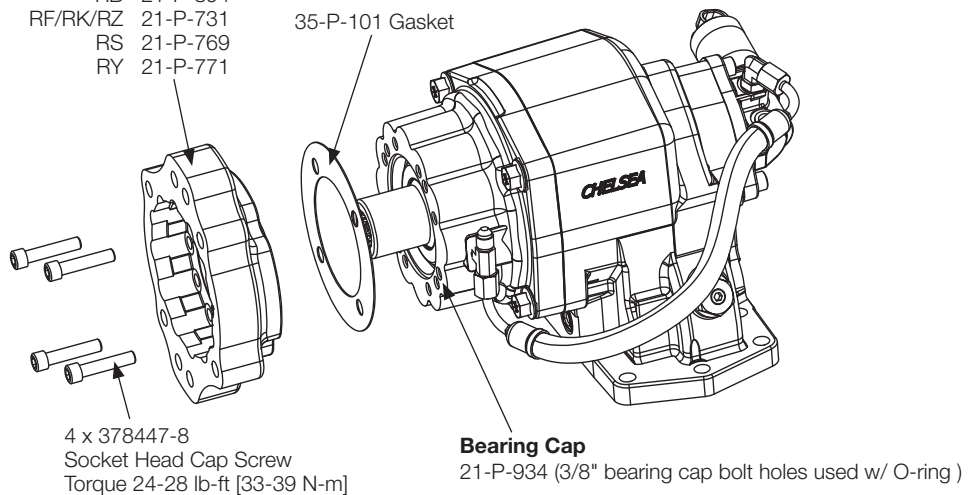

**Hydraulic Valve Cap Assembly**

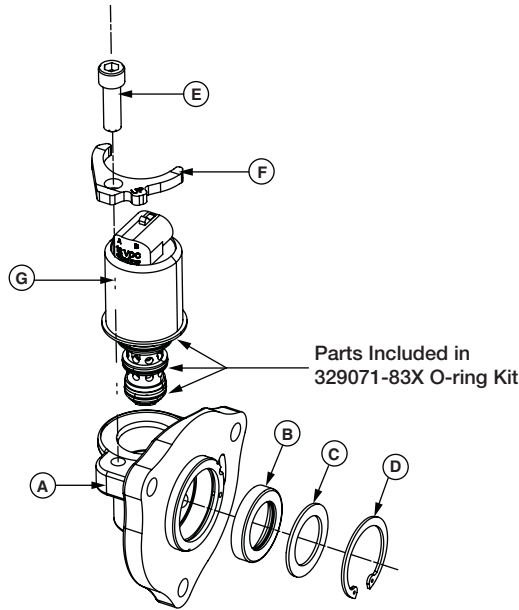

Item	Part Number	Description	Qty.
11	<b>329442-12X</b>	Valve & Cap Assembly (12VDC) (KV Gear Only) .....	1 or
	<b>329442-24X</b>	Valve & Cap Assembly (24VDC) (KV Gear Only) .....	1
	<b>329463-12X</b>	Valve & Cap Assembly (12VDC) (FJ Gear Only) .....	1 or
	<b>329463-24X</b>	Valve & Cap Assembly (24VDC) (FJ Gear Only) .....	1
A	<b>34-P-143</b>	Valve Cap .....	1
B	<b>28-P-119</b>	Oil Seal (High Pressure) .....	1
C	<b>378811</b>	Washer .....	1
D	<b>378849</b>	Snap Ring .....	1
E	<b>378447-6</b>	Socket Head Cap Screw (.312"-18 x 1.000") .....	1
F	<b>379995</b>	Clamp (KV) Included with 379993 Valve .....	1 or
	<b>380012</b>	Clamp (FJ) used w/ 380011 Valve .....	1
	<b>380124</b>	Clamp (FJ) used w/ 380123 Valve .....	1
G	<b>380123-12</b>	Hydraulic Valve (12VDC) (FJ) (White Connector Top) (New Style) .....	1 or
	<b>380123-24</b>	Hydraulic Valve (24VDC) (FJ) (Black Connector Top) (New Style) .....	1
	<b>380011-12</b>	Hydraulic Valve (12VDC) (FJ) (White Side Connector) N.L.A. – USE 380123-12 .....	1 or
	<b>380011-24</b>	Hydraulic Valve (24VDC) (FJ) (Black Side Connector) N.L.A. – USE 380123-24 .....	1
	<b>379993-12</b>	Hydraulic Valve (12VDC) (KV) (White Connector) .....	1 or
	<b>379993-24</b>	Hydraulic Valve (24VDC) (KV) (Black Connector) .....	1
	<b>329071-83X</b>	Hydraulic Solenoid Valve O-ring Service Kit .....	1
N.L.A. – No Longer Available			

**Remote Valve Cap Assembly - 329403X**

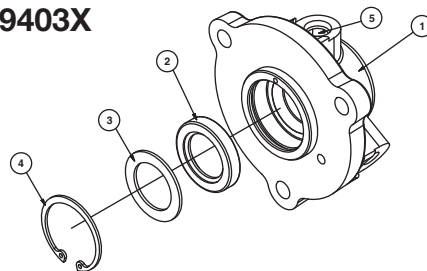

Item	Part Number	Description	Qty.
1	<b>21-P-701</b>	Cap Seal .....	1 or
2	<b>28-P-119</b>	Oil Seal (1.379" x .875" x .250") .....	1
3	<b>378811</b>	Washer .....	1
4	<b>378849</b>	Lockring .....	1
5	<b>500897-6</b>	Shipping Plug .....	2

Housing Dimensions

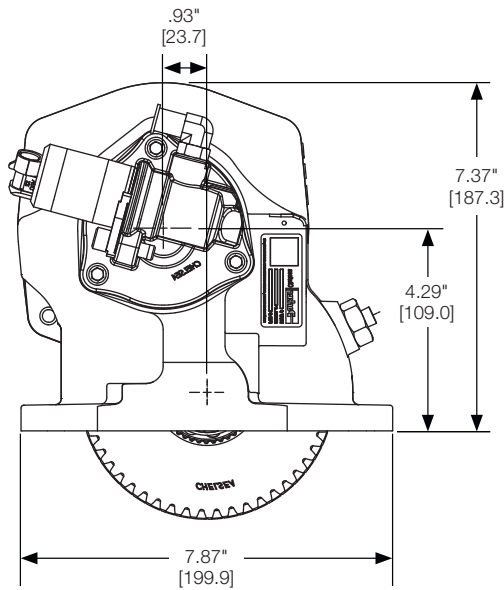

Assembly 3

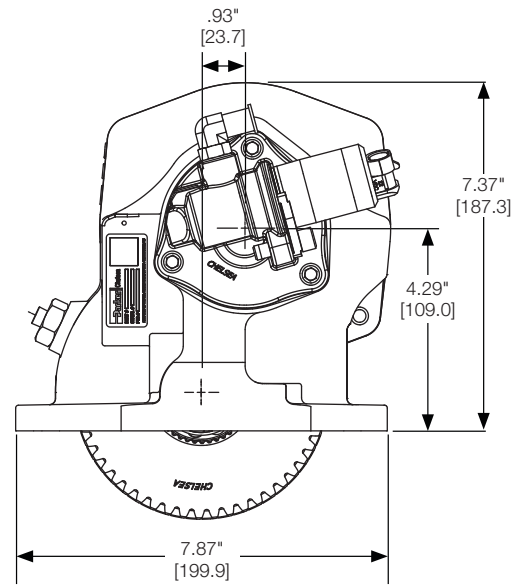

Assembly 5

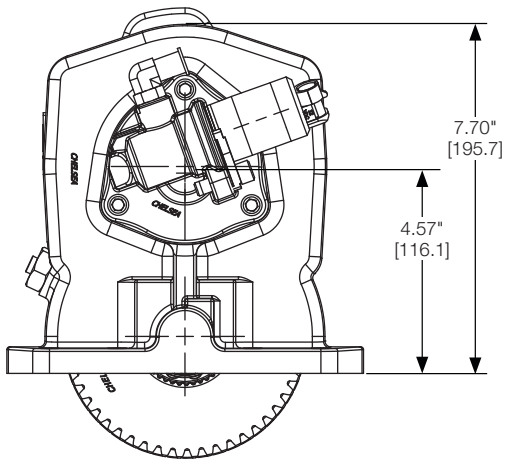

Assembly 8

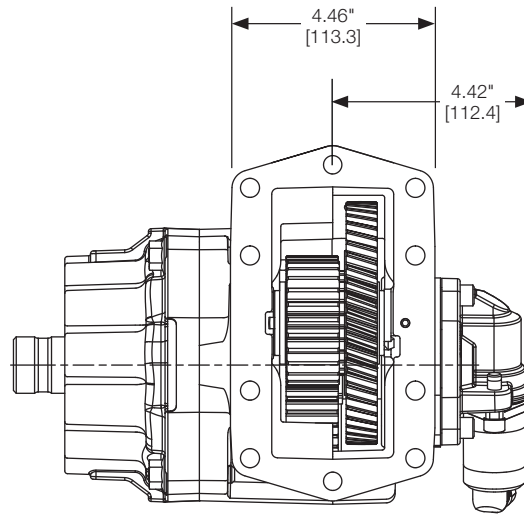

Output Options

Direct Mount Pump Flange & Shaft Dimensions

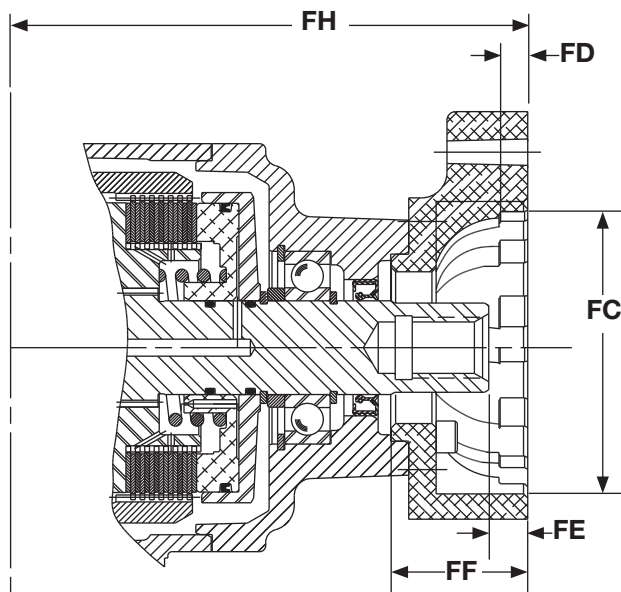

Direct Mount

Pump Flange Suffix	Bolt Circle Diameter	Bolt Holes		FC	FD	FE	FF	FH	Output Shaft
		Hole Diameter	No. Equally Spaced	Female Pilot of Flange	Pilot Depth Hole	Face to End of PTO	Face Thru	Face to Center	Dimensions
RB •	5.000"	1/2"-13 UNC	4	4.000"	.406"	.497"	1.872"	7.643"	7/8" - 13T Spline
RF •	5.750"	1/2"-13 UNC	2 ■	4.000"	.406"	.592"	2.060"	7.643"	1" - 15T Spline
	4								
RK •	5.750"	1/2"-13 UNC	2 ■	4.000"	.406"	.497"	1.872"	7.643"	7/8" - 13T Spline
	4								
RS •	7.125"	5/8"-11 UNC	2	5.003"	.531"	.730"	2.700"	7.671"	1-1/4" - 14T Spline
	6.375"	1/2"-13 UNC	4						
RY •	4.454"	M12-1.75	4	3.152"	.700"	.581"	2.281"	7.266"	B8x32x36
RZ •	5.750"	1/2"-13 UNC	2 ■	4.000"	.406"	.730"	2.700"	7.643"	1-1/4" - 14T Spline
	4								

Companion Flange Mount & Shaft Dimensions

Pump Flange Suffix	Bolt Circle Diameter	Bolt Holes		FC	FD	FE	FF	FH	Output Shaft
		Hole Diameter	No. Equally Spaced	Male/Female Pilot of Flange	Pilot Depth Hole	Face to End of PTO	Face Thru	Face to Center	Dimensions
AB, SB	3.996"	0.404" ▶	8	2.952"	.093" ◆	-	-	8.009"	1-1/2" - 10T Spline
AC, SC	3.307"	0.323" ▶	6	2.243"	.080" ◆	-	-	7.978"	1-1/4" Rd
BD	-	-	-	-	-	-	-	9.058"	1-1/4" Rd Keyed (5/16")
BV	3.750"	0.440" ▶	4	2.751"	.083"	-	-	8.986"	1-1/2" - 10T Spline
SD	-	-	-	-	-	-	-	6.570"	1-1/4" Keyed
XV, SV	3.750"	0.440" ▶	4	2.751"	.083"	-	-	8.956"	1-1/2" - 10T Spline

- Rotatable Flange Rotates in 30° Increments
- Two Set of Holes Spaced 14° Apart
- ▶ Not Tapped
- ◆ Pilot is Not a Hole

**CAUTION:** All pump mounting dimensions shown are compiled to conform to SAE/DIN standards; however it shall be the responsibility of the user to determine the correct fit at the time the pump is mounted to the PTO. Therefore carefully check the shaft and key or spline engagement.

**Drive Shaft & Clutch Assembly – 330155X**

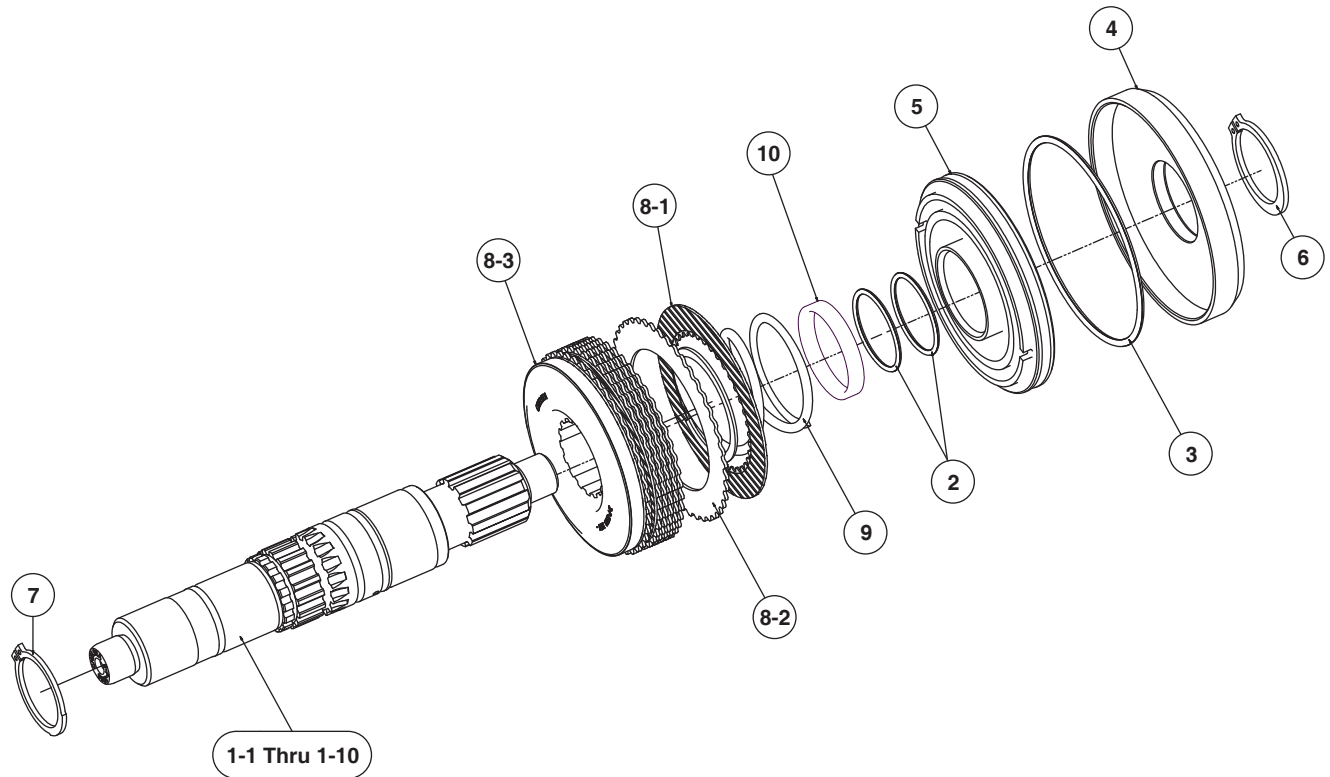

Item	Part Number	Description	Qty.
1-1	<b>3-P-1065</b>	Output Shaft 10T Straight (330155-1X).....	1 or
1-2	<b>3-P-1066</b>	Output Shaft (1-1/4" - 14T) (330155-2X).....	1 or
1-3	<b>3-P-1067</b>	Output Shaft DIN 8T (330155-3X).....	1 or
1-4	<b>3-P-1126</b>	Output Shaft (7/8" - 13T) (330155-4X).....	1 or
1-5	<b>3-P-1127</b>	Output Shaft (1" - 13T) (330155-5X).....	1 or
1-6	<b>3-P-1125</b>	Output Shaft (1.250") Keyed (330155-6X).....	1 or
1-8	<b>3-P-1161</b>	Output Shaft Straight w/ SmartStart 10T (330155-8X).....	1
1-9	<b>3-P-1156</b>	Output Shaft (1.250") Keyed w/ SmartStart (330155-9X).....	1
2	<b>28-P-285</b>	O-ring (1.597" x .103").....	2
3	<b>28-P-178</b>	O-ring (4.359" x .138").....	1
4	<b>380051</b>	Back up Cylinder Clutch.....	1
5	<b>380110-1</b>	Clutch Piston.....	1
6	<b>379555</b>	Lockring.....	1
7	<b>380069</b>	Lockring.....	1
8	<b>330154X</b>	Gear & Plates Kit.....	1
8-1	<b>379485</b>	Friction Disc.....	8
8-2	<b>379595</b>	Clutch Plate.....	7
8-3	<b>2-P-1038</b>	Inner Gear Clutch 36T.....	1
9	<b>37-P-72</b>	Spring (2.140" x .941").....	1
10	<b>4-P-213</b>	Spacer (1.800" x 2.070" x .330").....	1

**Output Options**

**Drive Shaft & Clutch Assembly – 330156X**  
**Shaft Brake Output - BD, BV**

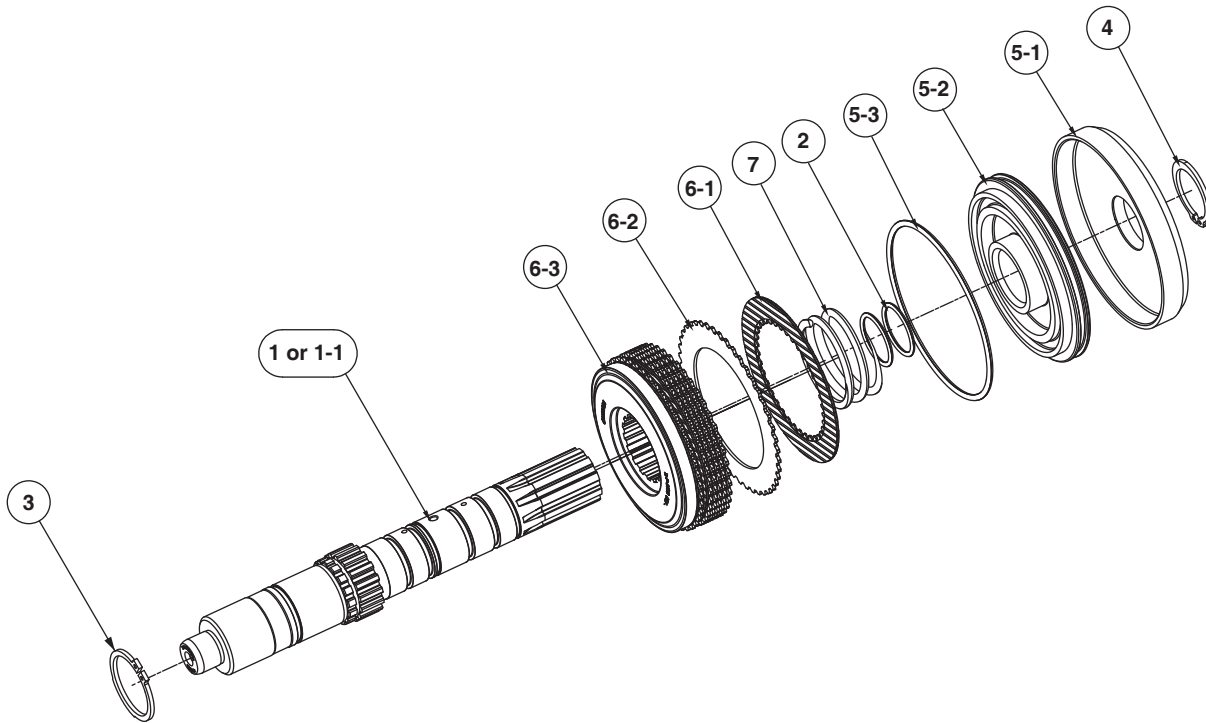

Item	Part Number	Description	Qty.
1	<b>3-P-1072</b>	Output Shaft 10T Straight (330156X) (BD, BV).....	1 or
1-1	<b>3-P-1141</b>	Output Shaft (1-1/4" Keyed) (330156-1X) (BD, BV) .....	1
2	<b>28-P-244</b>	O-ring (1.174" x .103").....	2
3	<b>380069</b>	Lockring .....	1
4	<b>378576</b>	Lockring .....	1
5	<b>329179-1X</b>	Piston & Back-Up Cylinder Assembly .....	1
5-1	<b>379323-1</b>	Cylinder Clutch Back-Up .....	1
5-2	<b>380057-1</b>	Piston Clutch Hydraulic.....	1
5-3	<b>28-P-178</b>	O-ring (4.359" x .138").....	1
6	<b>330154X</b>	Gear & Plates Kit .....	1
6-1	<b>379485</b>	Friction Disc.....	8
6-2	<b>380065</b>	Clutch Plate.....	7
6-3	<b>2-P-1038</b>	Output Gear .....	1
7	<b>37-P-39</b>	Spring (2.552" x 1.985") .....	1

**Output Options**

**Shaft Brake**

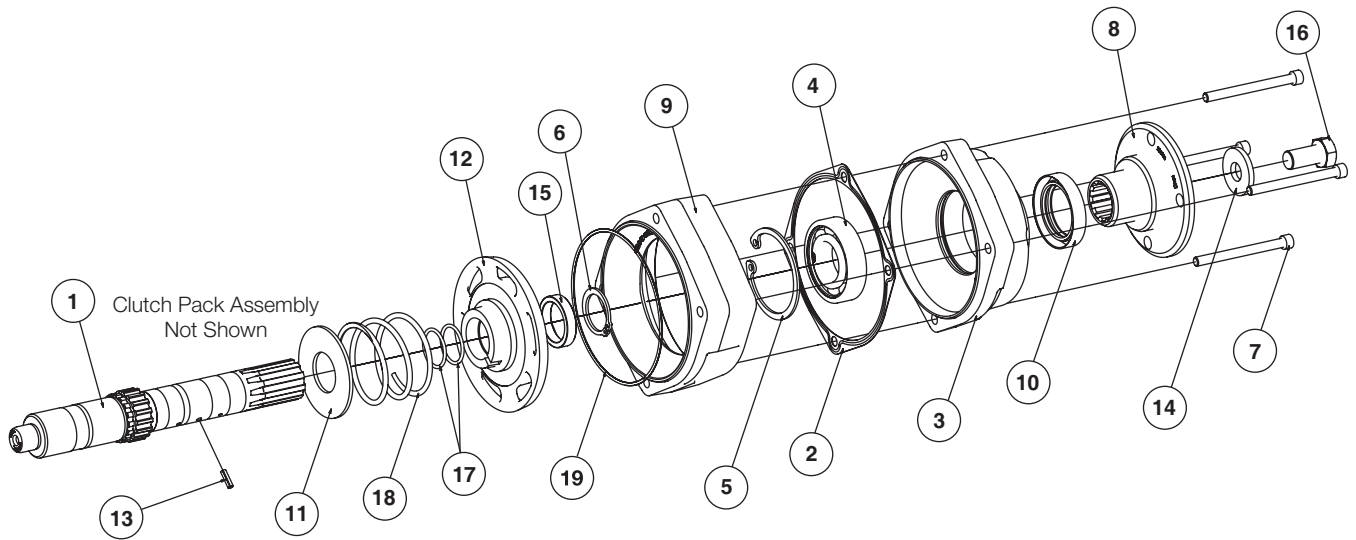

Output Flange	Part Number	Description	Qty.
1	<b>329723X</b>	<b>BV Assembly Drive Shaft &amp; Clutch (3-P-1072 Shaft) .....</b>	1
2	<b>22-P-151</b>	Gasket.....	1
3	<b>21-P-884</b>	Bearing Cap (w/ 3/8" Bearing Cap Bolts).....	1
4	<b>550010</b>	Bearing Ball (1.378" x 2.834" x .669").....	1
5	<b>378895</b>	Lockring .....	1
6	<b>378576</b>	Lockring .....	1
7	<b>380563-28</b>	Hex Flange Head Cap Screw (.375"-16 x 3.500") (w/ 3/8" Bearing Cap Bolts).....	4
8	<b>380081</b>	1410 Series Companion Flange (BV) .....	1
9	<b>23-P-73</b>	Drag Brake Bearing Cap Spacer (w/ 3/8" Bearing Cap Bolts w/ O-ring).....	1
10	<b>28-P-212</b>	Oil Seal (2.506" x 1.750" x .315").....	1
11	<b>31-P-113</b>	Thrust Washer (1.385" x 3.125" x .125").....	1
12	<b>329410X</b>	Brake Assembly .....	1
13	<b>379977</b>	Spring Pin.....	1
14	<b>4-P-130</b>	Washer.....	1
15	<b>4-P-186</b>	Spacer (1.385" x 1.750" x .365") .....	1
16	<b>378435-7</b>	Hex Head Cap Screw (.625"-11 x 1.250") .....	1
17	<b>28-P-244</b>	O-ring (1.174" x .103").....	2
18	<b>37-P-60</b>	Spring (2.531" x 2.130" x .172") .....	1
19	<b>28-P-329</b>	O-ring (5.487" x .103").....	1
1	<b>329723-1X</b>	<b>BD Assembly Drive Shaft &amp; Clutch (3-P-1141 Shaft).....</b>	1
2	<b>22-P-151</b>	Gasket.....	2
3	<b>21-P-888</b>	Bearing Cap (w/ 3/8" Bearing Cap Bolts).....	1
4	<b>550010</b>	Ball Bearing (1.378" x 2.834" x .669").....	2
5	<b>378895</b>	Lockring .....	1
6	<b>378576</b>	Lockring .....	2
7	<b>380563-28</b>	Hex Flange Head Cap Screw (.375"-16 x 3.500") (w/ 3/8" Bearing Cap Bolts).....	4
9	<b>23-P-73</b>	Drag Brake Bearing Cap Spacer (w/ 3/8" Bearing Cap Bolts) .....	1
10	<b>28-P-225</b>	Oil Seal (2.004" x 1.375" x .315").....	1
11	<b>31-P-113</b>	Thrust Washer (1.385" x 3.125" x .125").....	1
12	<b>329410X</b>	Assembly Brake .....	1
13	<b>379977</b>	Spring Pin.....	1
15	<b>4-P-186</b>	Spacer (1.385" x 1.750" x .365") .....	1
17	<b>28-P-244</b>	O-ring (1.174" x .103").....	2
18	<b>37-P-60</b>	Spring (2.531" x 2.130" x .172") .....	1
19	<b>28-P-329</b>	O-ring (5.487" x .103").....	1



Output Options

Bill of Materials - Driveline Output

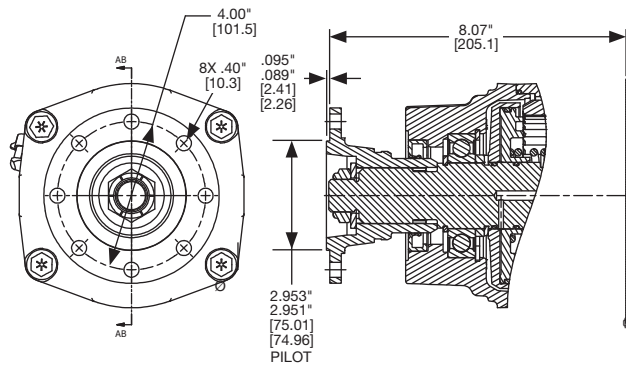

AB Output Option DIN 120 Flange		
Part Number	Description	Qty.
<b>330155-1X</b>	Drive Shaft & Clutch Assembly (3-P-1065 Shaft).....	1 or
<b>21-P-932</b>	Bearing Cap .....	1
<b>28-P-211</b>	Oil Seal (3.001" x 2.000" x .375").....	1
<b>379558</b>	Companion Flange DIN 120 .....	1
<b>380076-13</b>	Hardened Flat Washer (.950" x 1.762" x .157").....	1
<b>380486</b>	Thin Nylon Lock Nut (.875"-14).....	1
<b>329160-130X</b>	<b>Conversion Kit (Converts XD to AB)</b>	

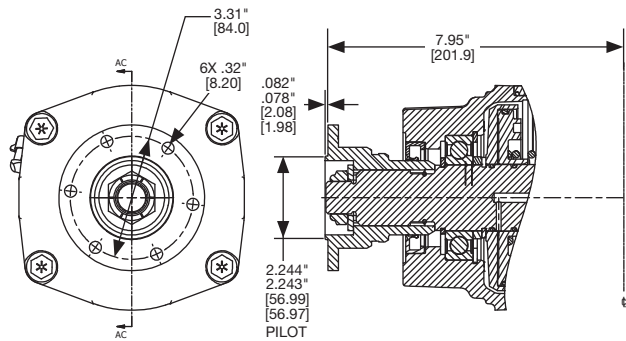

AC Output Options DIN 100 Flange		
Part Number	Description	Qty.
<b>330155-1X</b>	Drive Shaft & Clutch Assembly (3-P-1065 Shaft).....	1 or
<b>21-P-932</b>	Bearing Cap .....	1
<b>28-P-211</b>	Oil Seal (3.001" x 2.000" x .375").....	1
<b>379742</b>	Companion Flange DIN 100 .....	1
<b>380076-13</b>	Hardened Flat Washer (.950" x 1.762" x .157").....	1
<b>380486</b>	Thin Nylon Lock Nut (.875"-14).....	1
<b>329160-134X</b>	<b>Conversion Kit (Converts XD to AC)</b>	

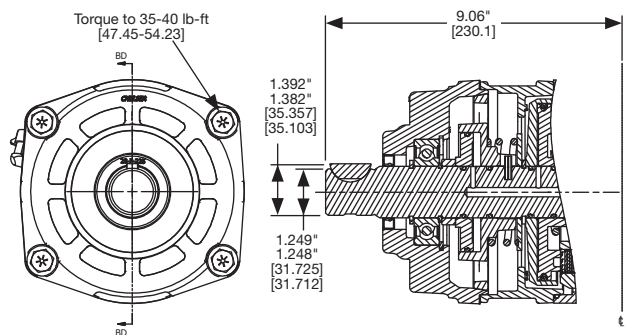

BD Output Option Drag Brake - Rd Standard Shaft (1-1/4" Dia w/ 5/16" Key)		
Part Number	Description	Qty.
<b>330156-1X</b>	Drive Shaft & Clutch Assembly.....	1
<b>22-P-151</b>	Shim Gasket.....	1
<b>21-P-888</b>	Drag Brake Bearing Cap.....	1
<b>550010</b>	Ball Bearing (1.378" x 2.834" x .669").....	1
<b>378895</b>	Lockring .....	1
<b>378576</b>	Lockring .....	2
<b>23-P-73</b>	Bearing Cap Drag Brake Spacer.....	1
<b>28-P-225</b>	Oil Seal (2.004" x 1.375" x .315").....	1
<b>31-P-113</b>	Thrust Washer (1.385" x 3.125" x .125").....	1
<b>329410X</b>	Brake Assembly .....	1
<b>379977</b>	Spring Pin (.187" x .625") .....	1
<b>4-P-186</b>	Spacer (1.385" x 1.750" x .365") .....	1
<b>28-P-244</b>	O-ring (1.174" x .103").....	2
<b>37-P-60</b>	Spring (2.531" x 2.130" x .172") .....	1
<b>28-P-329</b>	O-ring (5.487" x .103").....	1
<b>329160-136X</b>	<b>Conversion Kit (Converts XD to BD)</b>	



**Bill of Materials - Driveline Output (Continued)**

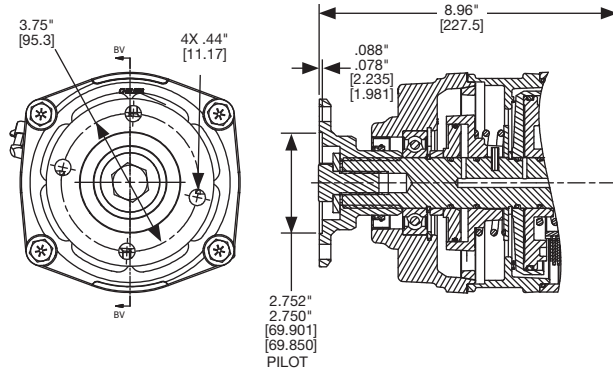

BV Output Option Drag Brake - 1410 Series Companion Flange		
Part Number	Description	Qty.
330156X	Drive Shaft & Clutch Assembly.....	1
22-P-151	Shim Gasket.....	1
21-P-884	Bearing Cap .....	1
550010	Ball Bearing (1.378" x 2.834" x .669").....	1
378895	Lockring .....	1
378576	Lockring .....	1
380563-28	Hex Flange Head Cap Screw (.375"-16 x 3.500") ..	4
380081	1410 Companion Flange .....	1
23-P-73	Bearing Cap Drag Brake Spacer.....	1
28-P-212	Oil Seal (2.506" x 1.750" x .315").....	1
31-P-113	Thrust Washer (1.385" x 3.125" x .125").....	1
329410X	Brake Assembly .....	1
379977	Spring Pin (.187" x .625"-236) .....	1
4-P-130	Spacer (.640" x 1.620" x .188") .....	1
4-P-186	Spacer (1.385" x 1.750" x .365") .....	1
378435-7	Hex Head Cap Screw (.625"-11 x 1.250") .....	1
28-P-244	O-ring (1.174" x .103").....	2
37-P-60	Spring (2.531" x 2.130" x .172") .....	1
28-P-329	O-ring (5.487" x .103") .....	1
329160-123X	<b>Conversion Kit (Converts XD to BV)</b>	

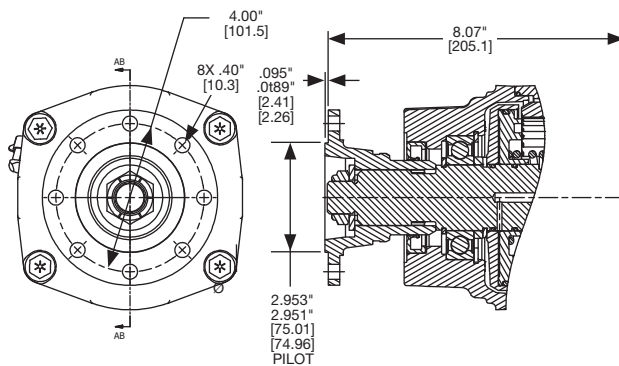

SB Output Options SmartStart - DIN 120 Flange		
Part Number	Description	Qty.
330155-8X	Drive Shaft & Clutch Assembly (3-P-1161 Shaft).....	1
21-P-932	Bearing Cap .....	1
28-P-211	Oil Seal (3.001" x 2.000" x .375").....	1
379558	Companion Flange DIN 120 .....	1
380076-13	Hardened Flat Washer (.950" x 1.762" x .157").....	1
380486	Thin Nylon Lock Nut (.875"-14).....	1
329160-131X	<b>Conversion Kit (Converts XD to SB)</b>	

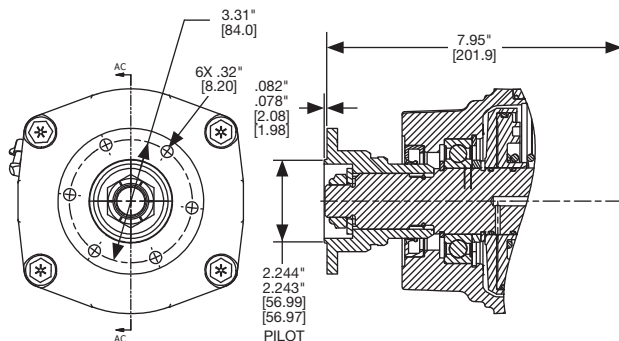

SC Output Options SmartStart - DIN 100 Flange		
Part Number	Description	Qty.
330155-8X	Drive Shaft & Clutch Assembly (3-P-1161 Shaft) Soft Start.....	1
21-P-932	Bearing Cap .....	1
28-P-211	Oil Seal (3.001" x 2.000" x .375").....	1
379742	Companion Flange DIN 100 .....	1
380076-13	Hardened Flat Washer (.950" x 1.762" x .157").....	1
380486	Thin Nylon Lock Nut (.875"-14).....	1
329160-135X	<b>Conversion Kit (Converts XD to SC)</b>	

Output Options

Bill of Materials - Driveline Output (Continued)

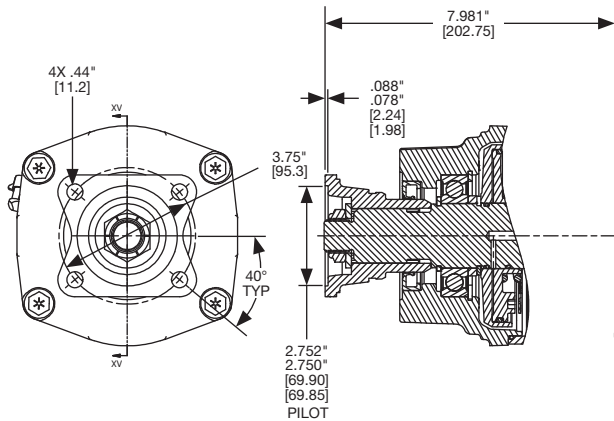

SV Output Options		
SmartStart - 1410 Series Companion Flange		
Part Number	Description	Qty.
330155-8X	Drive Shaft & Clutch Assembly (3-P-1161 Shaft) Soft Start.....	1
21-P-932	Bearing Cap .....	1
28-P-211	Oil Seal (3.001" x 2.000" x .375").....	1
380503	1410 Companion Flange .....	1
380076-13	Hardened Flat Washer (.950" x 1.762" x .157").....	1
380486	Thin Nylon Lock Nut (.875"-14).....	1
329160-120X	<b>Conversion Kit (Converts XD or XV to SV)</b>	

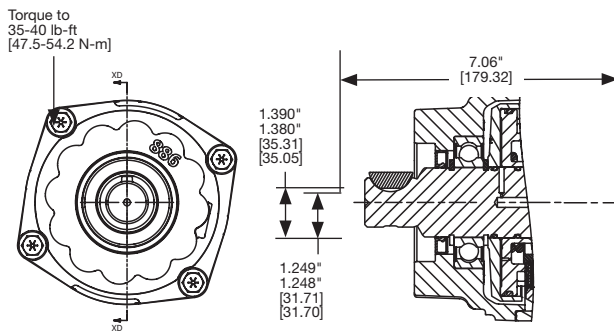

XD Output Option		
Rd Standard Shaft (1-1/4" - 5/16" Key)		
Part Number	Description	Qty.
330155-6X	Drive Shaft & Clutch Assembly (3-P-1125).....	1
21-P-932	Bearing Cap .....	1
28-P-267	Oil Seal (2.627" x 1.750" x .312").....	1
500007-29	5/16" Woodruff Key .....	1
329160-119X	<b>Conversion Kit (Converts XD to SD)</b>	

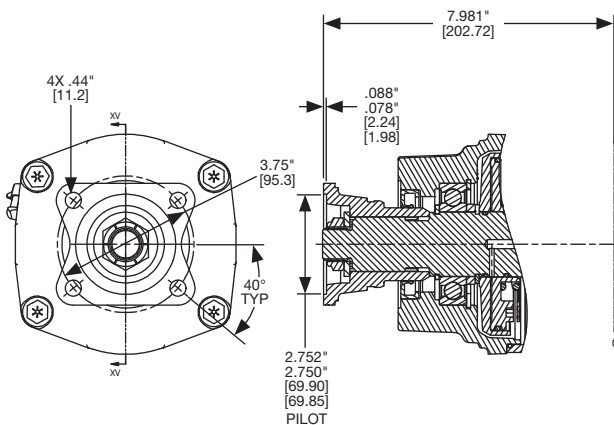

XV Output Options		
1410 Series Companion Flange		
Part Number	Description	Qty.
330155-1X	Drive Shaft & Clutch Assembly (3-P-1065 Shaft).....	1 or
21-P-932	Bearing Cap .....	1
28-P-211	Oil Seal (3.001" x 2.000" x .375").....	1
380503	1410 Companion Flange .....	1
380076-13	Hardened Flat Washer (.950" x 1.762" x .157").....	1
380486	Thin Nylon Lock Nut (.875"-14).....	1
329160-139X	<b>Conversion Kit (Converts XD to XV)</b>	

**Bill of Materials - Pump Mount**

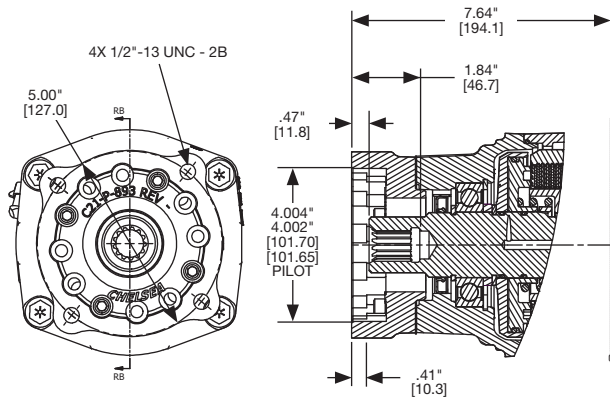

RB Output Option		
Rotatable SAE B 4-Bolt Flange, SAE B Shaft (7/8" - 13T)		
Part Number	Description	Qty.
330155-4X	Drive Shaft & Clutch Assembly (3-P-1126 Shaft).....	1
21-P-933	Bearing Cap .....	1 or
21-P-934	Bearing Cap (Wet Spline Only) .....	1
28-P-267	Oil Seal (2.627" x 1.750" x .312").....	1
328170-216X	Cap Screw Bag Kit (378447-8 Qty. 4).....	1
21-P-894	Pump Flange (Ship Loose w/ Unit).....	1
<b>WET SPLINE LOOSE PARTS KIT</b>		
329699-1X	Hose Assembly .....	1
329959X	Wet Spline Loose Parts Kit .....	1
329658X	Cover Kit .....	1
329160-164X	<b>Conversion Kit (Converts XD to RB)</b>	
329160-165X	<b>Conversion Kit (Converts XD to RB Wet Spline)</b>	

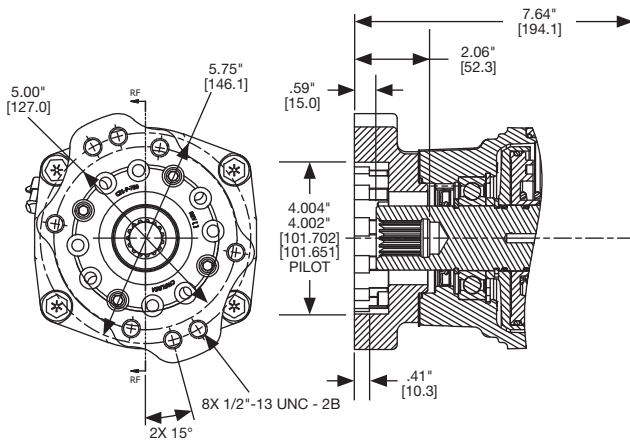

RF Output Option		
Rotatable SAE B 2 & 4-Bolt Flange, SAE BB Shaft (1" - 15T)		
Part Number	Description	Qty.
330155-5X	Drive Shaft & Clutch Assembly (3-P-1127 Shaft).....	1
21-P-933	Bearing Cap .....	1 or
21-P-934	Bearing Cap (Wet Spline Only) .....	1
28-P-267	Oil Seal (2.627" x 1.750" x .312").....	1
328170-216X	Cap Screw Bag Kit (378447-8 Qty. 4).....	1
35-P-101	Wet Spline Bearing Cap Gasket (Ships w/ Kit) .....	1
21-P-731	Pump Flange (Ship Loose w/ Unit).....	1
<b>WET SPLINE LOOSE PARTS</b>		
329699-1X	Assembly Hose .....	1
329700X	Wet Spline Loose Parts Kit .....	1
329658X	Cover Kit .....	1
329160-156X	<b>Conversion Kit (Converts XD to RF)</b>	
329160-157X	<b>Conversion Kit (Converts XD to RF Wet Spline)</b>	

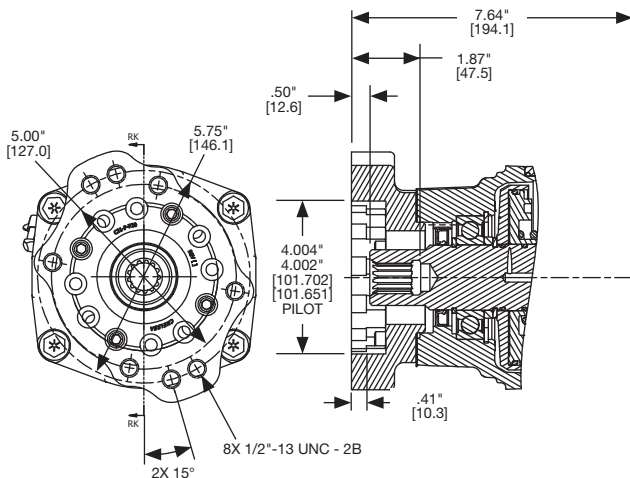

RK Output Option		
Rotatable SAE B 2 & 4-Bolt Flange, SAE B Shaft (7/8" - 13T)		
Part Number	Description	Qty.
330155-4X	Drive Shaft & Clutch Assembly (3-P-1126 Shaft).....	1
21-P-933	Bearing Cap .....	1 or
21-P-934	Bearing Cap (Wet Spline Only) .....	1
28-P-267	Oil Seal (2.627" x 1.750" x .312").....	1
328170-216X	Cap Screw Bag Kit (378447-8 Qty. 4).....	1
35-P-101	Wet Spline Bearing Cap Gasket (Ships w/ Kit) .....	1
21-P-731	Pump Flange (Ship Loose w/ Unit).....	1
<b>WET SPLINE LOOSE PARTS</b>		
329699-1X	Assembly Hose .....	1
329700X	Wet Spline Loose Parts Kit .....	1
329658X	Cover Kit .....	1
329160-154X	<b>Conversion Kit (Converts XD to RK)</b>	
329160-155X	<b>Conversion Kit (Converts XD to RK Wet Spline)</b>	

Output Options

Bill of Materials - Pump Mount (Continued)

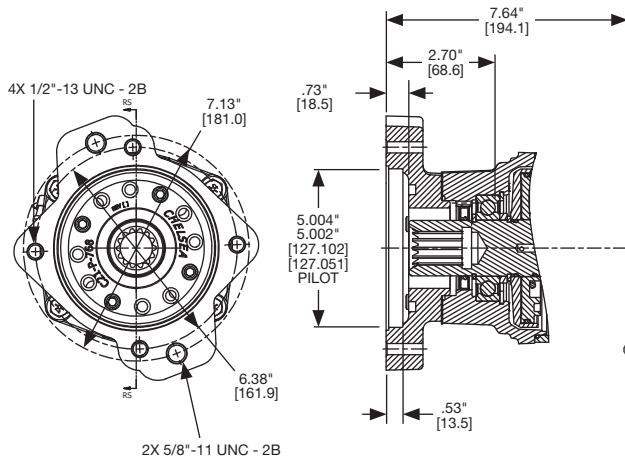

RS Output Option		
Rotatable SAE C 2 & 4-Bolt Flange, SAE C Shaft (1-1/4" - 14T)		
Part Number	Description	Qty.
<b>330155-2X</b>	Drive Shaft & Clutch Assembly (3-P-1066 Shaft).....	1
<b>21-P-934</b>	Bearing Cap (Wet Spline Only).....	1
<b>21-P-933</b>	Bearing Cap.....	1 or
<b>28-P-267</b>	Oil Seal (2.627" x 1.750" x .312").....	1
<b>328170-216X</b>	Cap Screw Bag Kit (378447-8 Qty. 4).....	1
<b>35-P-101</b>	Wet Spline Bearing Cap Gasket (Ships w/ Kit).....	1
<b>21-P-769</b>	Pump Flange (Ship Loose w/ Unit).....	1
<b>Wet Spline LOOSE PARTS</b>		
<b>329699-1X</b>	Hose Assembly.....	1
<b>329744X</b>	Wet Spline Loose Parts Kit.....	1
<b>329654X</b>	Cover Kit.....	1
<b>329160-158X</b>	<b>Conversion Kit (Converts XD to RS Wet Spline)</b>	
<b>329160-159X</b>	<b>Conversion Kit (Converts XD to RS)</b>	

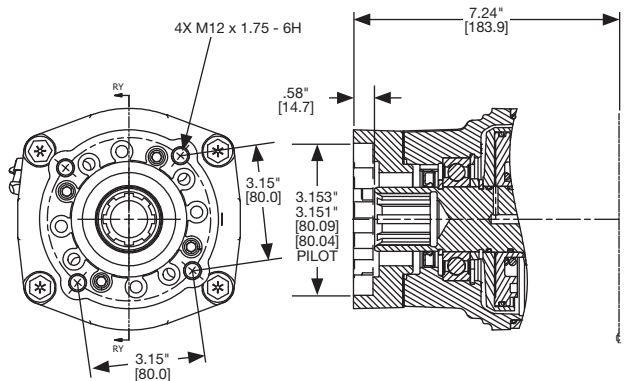

RY Output Option		
Rotatable DIN 5462 Pump Mounting, DIN 5462 Shaft (B8x32x36)		
Part Number	Description	Qty.
<b>330155-3X</b>	Drive Shaft & Clutch Assembly (3-P-1067 Shaft).....	1
<b>21-P-933</b>	Bearing Cap.....	1 or
<b>21-P-934</b>	Bearing Cap (Wet Spline Only).....	1
<b>28-P-267</b>	Oil Seal (2.627" x 1.750" x .312").....	1
<b>328170-216X</b>	Cap Screw Bag Kit (378447-8 Qty. 4).....	1
<b>35-P-101</b>	Wet Spline Bearing Cap Gasket (Ships w/ Kit).....	1
<b>21-P-771</b>	Pump Flange (Ship Loose w/ Unit).....	1
<b>WET SPLINE LOOSE PARTS</b>		
<b>329699-1X</b>	Assembly Hose.....	1
<b>329742X</b>	Wet Spline Loose Parts Kit.....	1
<b>329659X</b>	Cover Kit.....	1
<b>329160-160X</b>	<b>Conversion Kit (Converts XD to RY)</b>	
<b>329160-161X</b>	<b>Conversion Kit (Converts XD to RY Wet Spline)</b>	

**Bill of Materials - Pump Mount (Continued)**

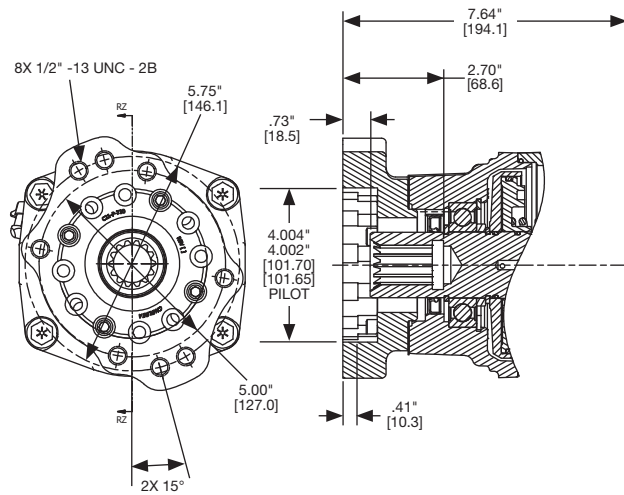

RZ Output Option		
Rotatable SAE B 2 & 4-Bolt Flange, SAE C Shaft (1-1/4" - 14T)		
Part Number	Description	Qty.
<b>330155-2X</b>	Drive Shaft & Clutch Assembly (3-P-1066 Shaft).....	1
<b>21-P-933</b>	Bearing Cap .....	1 or
<b>21-P-934</b>	Bearing Cap (Wet Spline Only) .....	1
<b>28-P-267</b>	Oil Seal (2.627" x 1.750" x .312").....	1
<b>328170-216X</b>	Cap Screw Bag Kit (378447-8 Qty. 4).....	1
<b>35-P-101</b>	Wet Spline Bearing Cap Gasket (Ships w/ Kit) .....	1
<b>21-P-731</b>	Pump Flange (Ship Loose w/ Unit).....	1
<b>WET SPLINE LOOSE PARTS</b>		
<b>329699-1X</b>	Hose Assembly .....	1
<b>329700X</b>	Wet Spline Loose Parts Kit .....	1
<b>329658X</b>	Cover Kit	
<b>329160-162X</b>	<b>Conversion Kit (Converts XD to RZ Wet Spline)</b>	
<b>329160-163X</b>	<b>Conversion Kit (Converts XD to RZ)</b>	

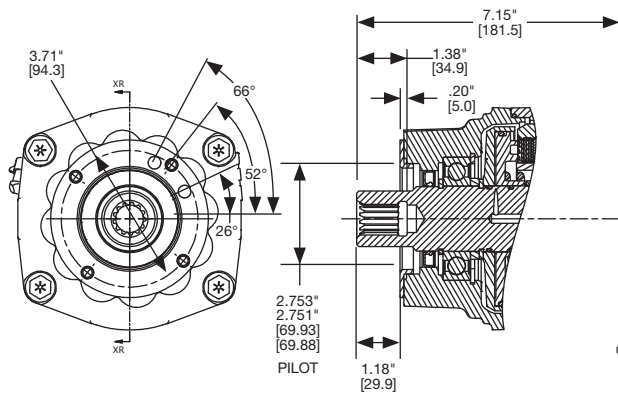

XR Output Option		
Parker P16 S Flange, SAE B Shaft (7/8" - 13T)		
Part Number	Description	Qty.
<b>330155-4X</b>	Drive Shaft & Clutch Assembly (3-P-1126 Shaft).....	1
<b>21-P-933</b>	Bearing Cap .....	1
<b>28-P-267</b>	Oil Seal (2.627" x 1.750" x .312").....	1
<b>380563-14</b>	Cap Screw (.375"-16 x 1.500").....	4
<b>4-P-209</b>	Spacer (XR) (Included in Kit).....	1
<b>329906X</b>	Pump Installation Kit (XR).....	1

†Conversion Kits do not include all parts listed above. See page 49 for Conversion Kit BOMs.









**Allison 3000/4000 Transmission  
 Shift Option G & H  
 Elec/Hyd w/ Remote Mount Solenoid  
 281 Series**

**(SK-432 Rev H)**

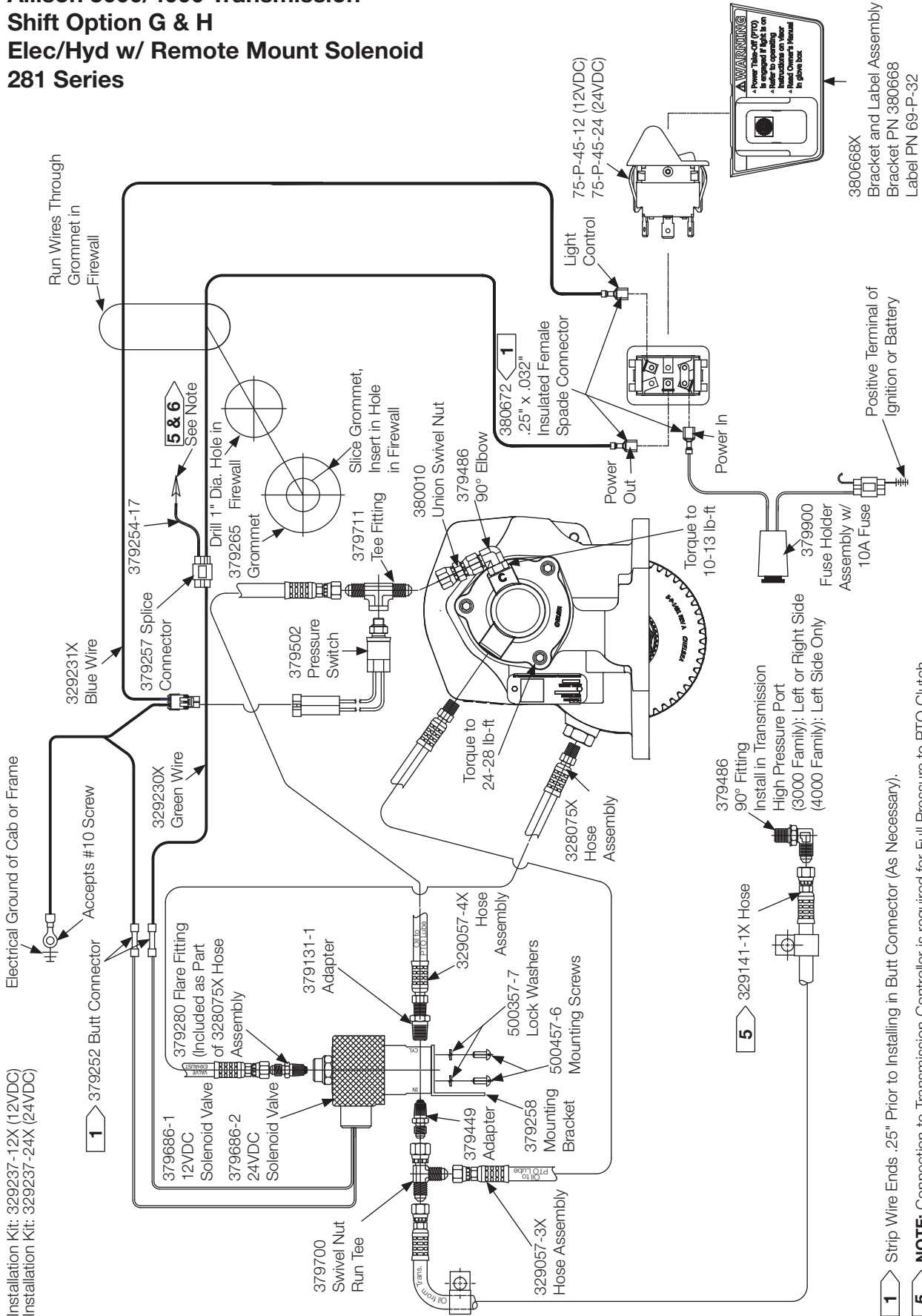

Installation Kit: 329237-12X (12VDC)  
 Installation Kit: 329237-24X (24VDC)

- 1** Strip Wire Ends .25" Prior to Installing in Butt Connector (As Necessary).
- 5** NOTE: Connection to Transmission Controller is required for Full Pressure to PTO Clutch.
- 6** To maintain proper hydraulic pressure to PTO clutch, connect Chelsea specified wire to Allison "PTO Request" circuit wire/pin within transmission TCM. Location of PTO Request wire/pin is dependent on Transmission Location Code. For assistance, contact your local Allison representative or contact Allison Technical Assistance at 1-800-252-5283.



**Allison 3000/4000 Transmission**  
**Shift Option S & T**  
**Elec/Hyd w/ PTO/Pump Combo Valve**  
**281 Series**

**(SK-427 Rev E)**

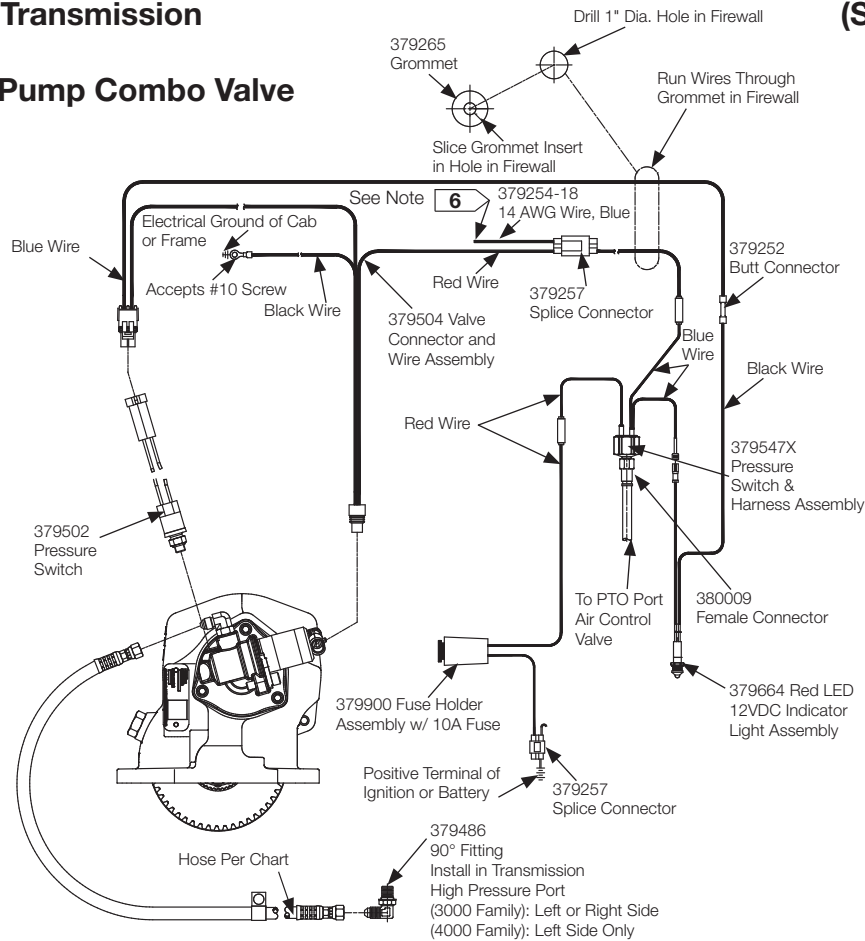

**6** To maintain proper hydraulic pressure to PTO clutch, connect Chelsea specified wire to Allison "PTO Request" circuit wire/pin within transmission TCM. Location of PTO Request wire/pin is dependent on Transmission Location Code. For assistance, contact your local Allison representative or contact Allison Technical Assistance at 1-800-252-5283.

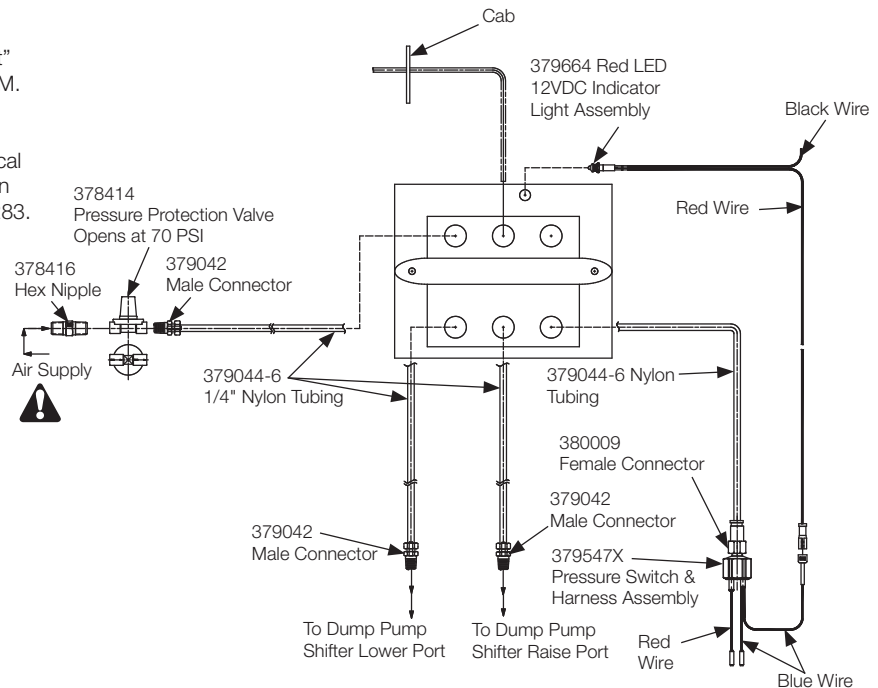

Installation Kit: (S Shift) 328388-85X  
 Installation Kit: (T Shift) 328388-86X

**NOTE:** Air control valve must be fitted inside a waterproof housing when installed outside the driver's cab.

**WARNING:** Connect directly to air supply. Do not use tubing between air supply and pressure protection valve.

**Caution:** When installing nylon tubing avoid sharp angles, exhaust, and manifold systems.

**Pressure Port Locations & Hose Chart**

**(SK-414 Rev A)**

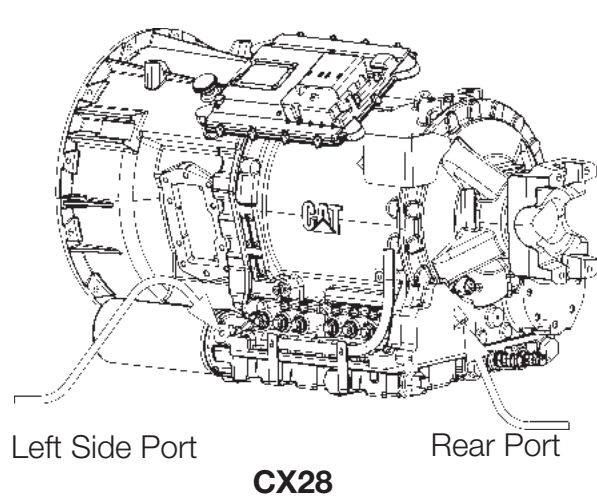
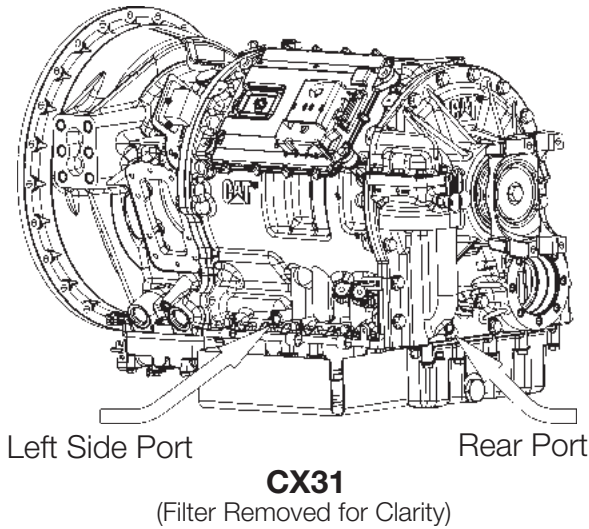

**Both High Pressure Connections are -4 O-ring Boss**

<b>HOSE CHART</b>							
<b>Trans.</b>	<b>PTO</b>	<b>PTO Location</b>	<b>High Oil Pressure Location</b>	<b>PTO Valve Location</b>	<b>PTO Fitting</b>	<b>Trans. Fitting</b>	<b>Trans.-PTO Valve Hose #</b>
CX31 CX28	281	Driver (LHS)	LHS	Attached	379486	379812	329075-1X
		Driver (LHS)	Rear				329075-5X
		Pass. (RHS)	LHS				329075-2X
		Pass. (RHS)	Rear				329075-5X
		Driver (LHS)	LHS	Remote	379486	379812	329130-6X
		Driver (LHS)	Rear				329130-6X
		Pass. (RHS)	LHS				329130-6X
		Pass. (RHS)	Rear				329130-6X

LHS = Left Hand Side of Transmission, 8 O'clock position  
 RHS = Right Hand Side of Transmission, 1 O'clock position

**NOTES:**

1. One PTO Fitting 379486 and one transmission fitting 379812 are included with the PTO unit.  
 If using 379486 in transmission it must be purchased separately.
2. 379486 elbow will not install on left hand (driver) side oil port due to transmission interference.
3. If 379486 is listed as transmission fitting for rear location, route hose along right hand (passenger) side of transmission and under transmission output yoke.



**Caterpillar CX28 & CX31 Transmission  
 Shift Option K & L  
 Elec/Hyd w/ EOC  
 281 Series**

**(SK-473 Rev B)**

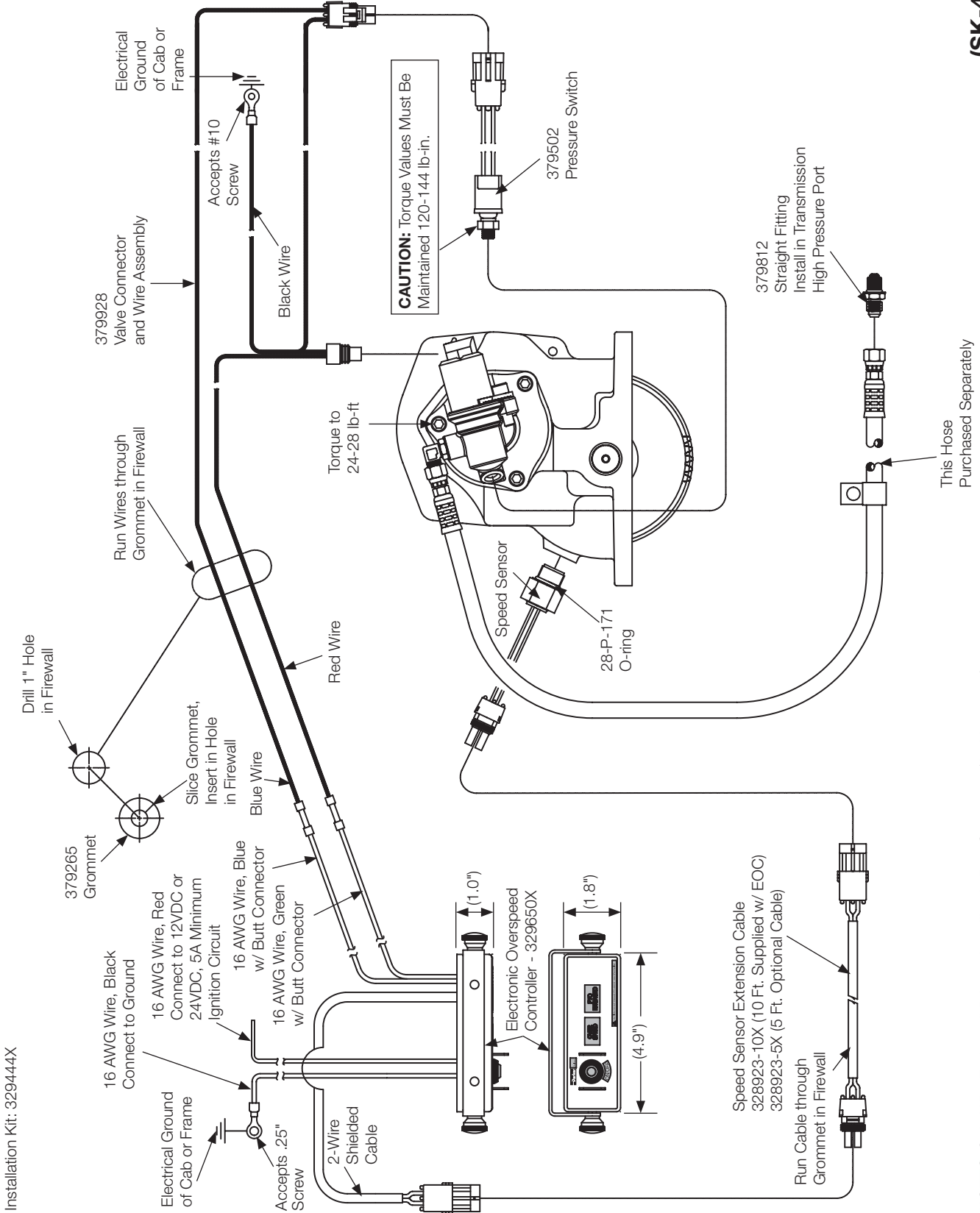

Installation Kit: 329444X

**NOTES:** Strip Wire Ends .25" Prior to Installing in Butt Connector (As Necessary).

**Caterpillar CX28 & CX31 Transmission  
 Shift Option G & H  
 Elec/Hyd w/ Remote Mount Solenoid  
 281 Series**

**(SK-413 Rev E)**

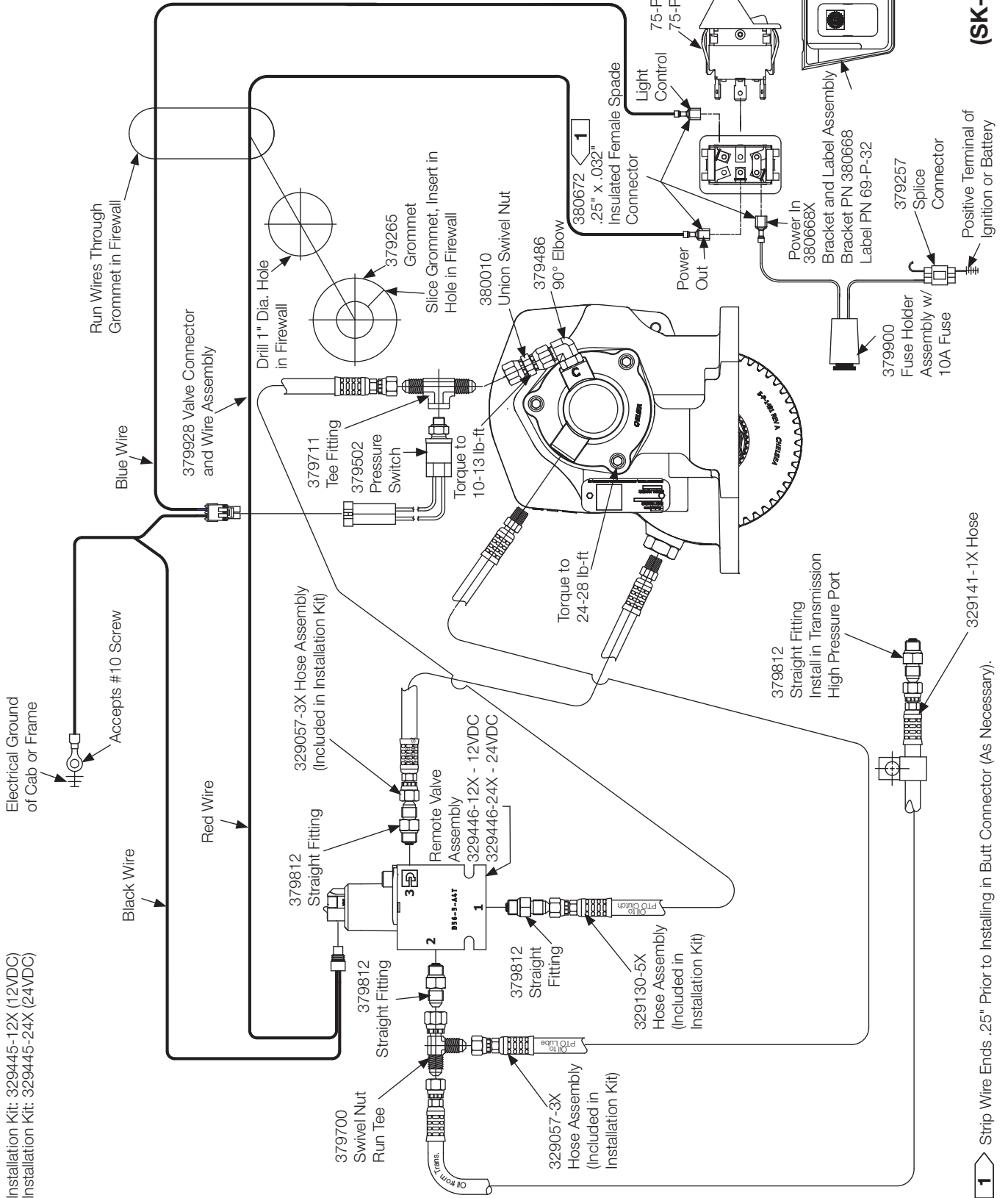

Installation Kit: 329445-12X (12VDC)  
 Installation Kit: 329445-24X (24VDC)

**1** Strip Wire Ends .25" Prior to Installing in Butt Connector (As Necessary).



**Model Number Designator**

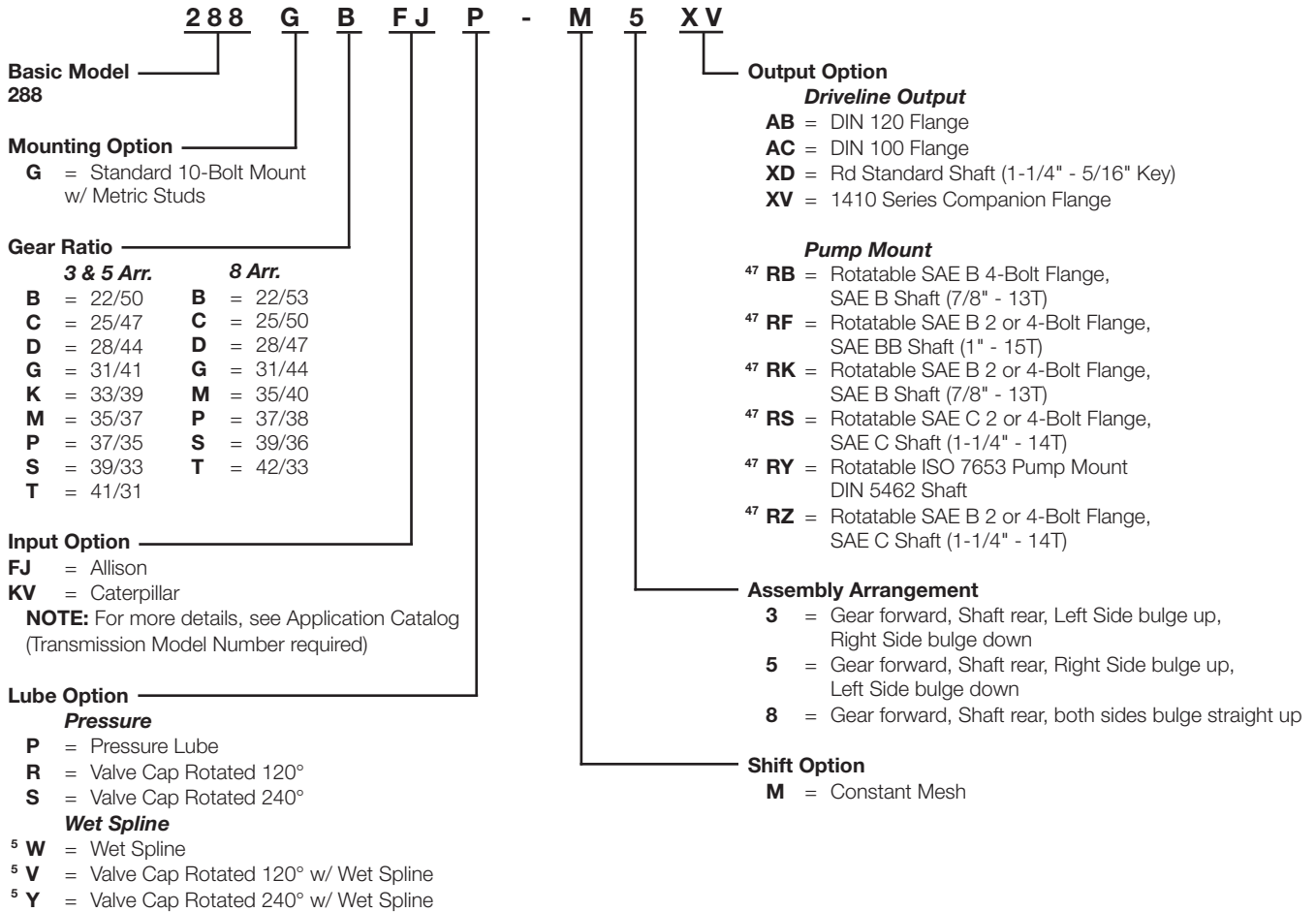

<sup>5</sup> Automatically Pressure Lubed  
<sup>47</sup> Available with Wet Spline

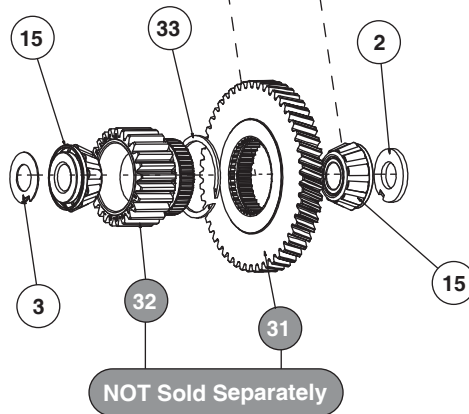
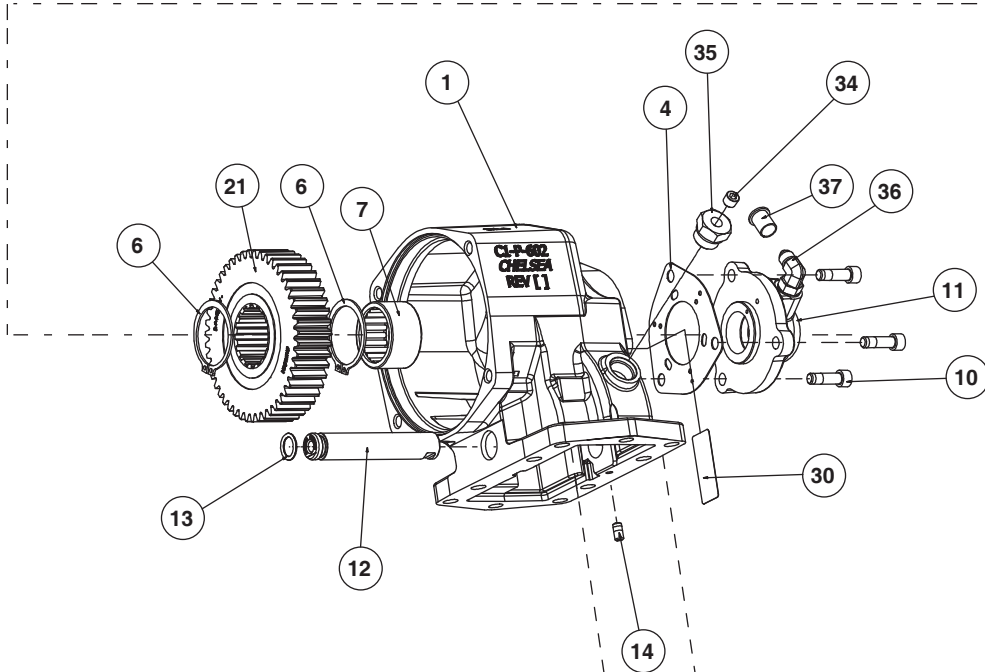
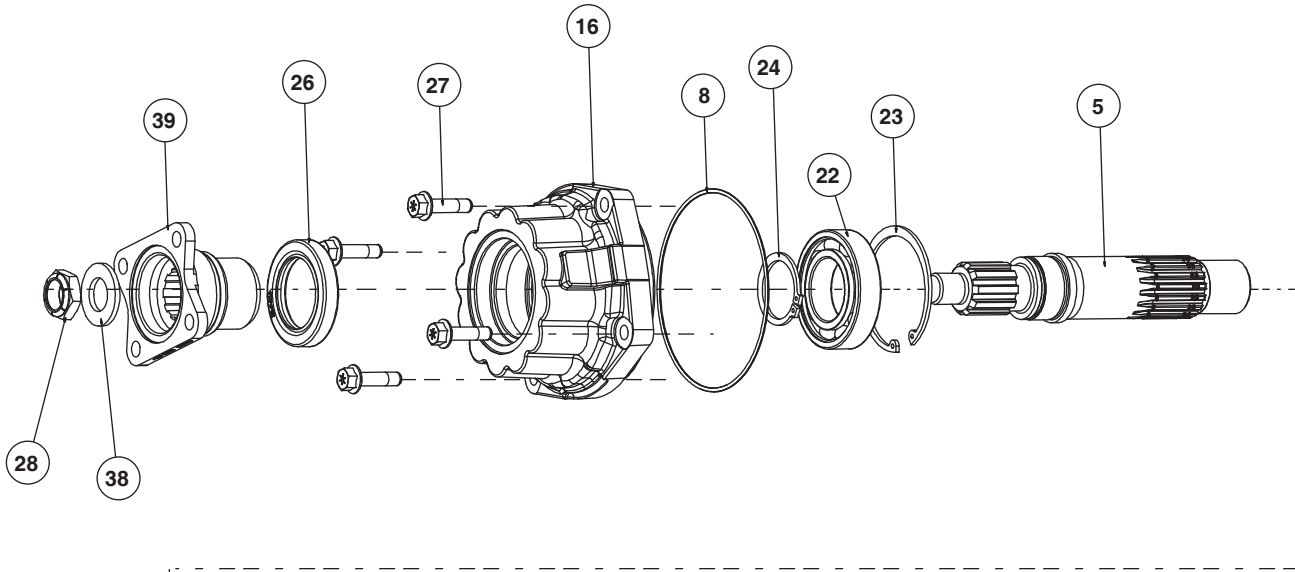



**Bill of Materials**

Item	Part Number	Description	Qty.
1	<b>1-P-813</b>	Housing (3 Arrangement with O-ring).....	1 or
	<b>1-P-814</b>	Housing (5 Arrangement with O-ring).....	1 or
	<b>1-P-815</b>	Housing (8 Arrangement with O-ring).....	1
2	<b>14-P-73-1</b>	Spacer (.762" x 1.500" x .150") (Thickness as Required).....	1 or
	<b>14-P-73-2</b>	Spacer (.762" x 1.500" x .153").....	1
	<b>14-P-73-3</b>	Spacer (.762" x 1.500" x .156").....	1
3	<b>31-P-102</b>	Thrust Washer (.754" x .440" x .030").....	1
4	<b>22-P-112</b>	Valve Cap Gasket.....	1
5	<b>3-P-1068</b>	10T Straight Output Shaft.....	1
6	<b>379668</b>	Lockring.....	2
7	<b>560972</b>	Needle Roller Bearing Assembly (1.500" x 1.875" x 1.000").....	1
8	<b>28-P-329</b>	O-ring (5.487" x .103").....	1
10	<b>378447-6</b>	Socket Head Cap Screw (.312"-18 x 1.000").....	3
11	<b>21-P-690</b>	Seal Cap.....	3
12	<b>9-P-106</b>	Idler Shaft (.750").....	1
13	<b>28-P-191</b>	O-ring (.549" x .103").....	1
14	<b>378452-7</b>	Socket Head Set Screw (.250"-20 x .500").....	1
15	<b>550439</b>	Tapered Bearing Cone (.750" x .859").....	2 or
15	<b>561006</b>	Tapered Bearing Cone (.750" x .655").....	2
16	<b>21-P-932</b>	Bearing Cap (XD, XV).....	1
21	<a href="#">See page 35</a>	Output Gear.....	1
22	<b>550311</b>	Ball Bearing (1.770" x 3.346" x .748").....	1
23	<b>378263</b>	Internal Lockring.....	1
24	<b>379555</b>	Lockring.....	1
26	<b>28-P-211</b>	Oil Seal (3.001" x 2.000" x .375").....	1
27	<b>380563-14</b>	Hex Flange Head Cap Screw (3/8"-16 x 1.500").....	4
28	<b>380486</b>	Thin Nylon Lock Nut (.875"-14).....	1
30	<b>68-P-51-1</b>	Adhesive Label.....	1
<b>Not Sold Separately</b>			
31	<a href="#">See page 35</a>	Input Gear.....	1
32	<a href="#">See page 35</a>	Ratio Gear.....	1
33	<b>379522</b>	Lockring.....	1
34	<b>379231</b>	Pipe Plug (.125"-27).....	1
35	<b>379242</b>	Straight Adapter (.125"-27 x .750"-16).....	1
36	<b>379486</b>	90° Elbow (.438"-20).....	1
37	<b>379564-2</b>	Thread Cap (.438").....	1
38	<b>380076-13</b>	Hardened Flat Washer (.950" x 1.762" x .157").....	1
39	<b>380503</b>	1410 Companion Flange (XV).....	1

Continued on Next Page

**Bill of Materials**

Item	Part Number	Description	Qty.
		<b>SERVICE KITS</b>	
	<b>329071-66X</b>	Bearing Kit	
	<b>329071-80X</b>	Gasket & Seal Kit	
		<b>STUD KITS</b>	
	<b>7170-86X</b>	Mounting Kit (FJ Input Option, 3 & 5 Arrangement) .....	1
	<b>7170-117X</b>	Mounting Kit (KV Input Option, 3 & 5 Arrangement) .....	1
		<b>INSTALLATION INSTRUCTIONS KIT</b>	
	<b>328948-47X</b>	Gasket & Installation Instructions Kit .....	1
		<b>HOSE ASSEMBLIES</b>	
	<b>329075-5X</b>	Pressure Hose Assembly (KV Input Option).....	1
	<b>329141-1X</b>	Pressure Hose Assembly (FJ Input Option) .....	1
	<b>329699-1X</b>	Wet Spline Lube Hose Assembly (W, V, Y Shift Option) .....	1

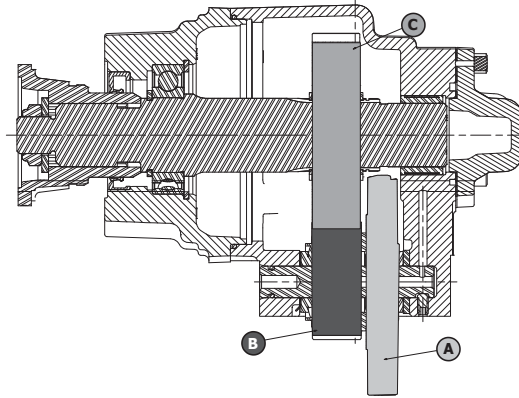

**3 and 5 Assembly**

GEAR DESIGNATOR	INPUT GEAR ASSEMBLY	NOT Sold Separately				OUTPUT GEAR (21)	NO. TEETH C
		INPUT GEAR (31)	NO. TEETH A	RATIO GEAR (32)	NO. TEETH B		
288*BFJ	5-P-1491-1X	5-P-1491	50	5-P-1478	22	2-P-944	50
288*CFJ	5-P-1491-2X	5-P-1491	50	5-P-1495	25	2-P-945	47
288*DFJ	5-P-1491-3X	5-P-1491	50	5-P-1479	28	2-P-946	44
288*GFJ	5-P-1491-4X	5-P-1491	50	5-P-1480	31	2-P-947	41
288*KFJ	5-P-1491-5X	5-P-1491	50	5-P-1481	33	2-P-949	39
288*MFJ	5-P-1491-6X	5-P-1491	50	5-P-1482	35	2-P-951	37
288*PFJ	5-P-1491-7X	5-P-1491	50	5-P-1483	37	2-P-953	35
288*SFJ	5-P-1491-8X	5-P-1491	50	5-P-1484	39	2-P-954	33
288*TFJ	5-P-1491-9X	5-P-1491	50	5-P-1497	41	2-P-955	31
288*BKV	5-P-1493-1X	5-P-1493	45	5-P-1478	22	2-P-944	50
288*CKV	5-P-1493-2X	5-P-1493	45	5-P-1495	25	2-P-945	47
288*DKV	5-P-1493-3X	5-P-1493	45	5-P-1479	28	2-P-946	44
288*GKV	5-P-1493-4X	5-P-1493	45	5-P-1480	31	2-P-947	41
288*KKV	5-P-1493-5X	5-P-1493	45	5-P-1481	33	2-P-949	39
288*MKV	5-P-1493-6X	5-P-1493	45	5-P-1482	35	2-P-951	37
288*PKV	5-P-1493-7X	5-P-1493	45	5-P-1483	37	2-P-953	35
288*SKV	5-P-1493-8X	5-P-1493	45	5-P-1484	39	2-P-954	33
288*TKV	5-P-1493-9X	5-P-1493	45	5-P-1497	41	2-P-955	31

**8 Assembly**

GEAR DESIGNATOR	INPUT GEAR ASSEMBLY	NOT Sold Separately				OUTPUT GEAR (21)	NO. TEETH C
		INPUT GEAR (31)	NO. TEETH A	RATIO GEAR (32)	NO. TEETH B		
288*BFJ	5-P-1491-1X	5-P-1491	50	5-P-1478	22	2-P-943	53
288*CFJ	5-P-1491-2X	5-P-1491	50	5-P-1495	25	2-P-944	50
288*DFJ	5-P-1491-3X	5-P-1491	50	5-P-1479	28	2-P-945	47
288*GFJ	5-P-1491-4X	5-P-1491	50	5-P-1480	31	2-P-946	44
288*MFJ	5-P-1491-6X	5-P-1491	50	5-P-1482	35	2-P-948	40
288*PFJ	5-P-1491-7X	5-P-1491	50	5-P-1483	37	2-P-950	38
288*SFJ	5-P-1491-8X	5-P-1491	50	5-P-1484	39	2-P-952	36
288*TFJ	5-P-1491-10X	5-P-1491	50	5-P-1485	42	2-P-954	33
288*BKV	5-P-1493-1X	5-P-1493	45	5-P-1478	22	2-P-943	53
288*CKV	5-P-1493-2X	5-P-1493	45	5-P-1495	25	2-P-944	50
288*DKV	5-P-1493-3X	5-P-1493	45	5-P-1479	28	2-P-945	47
288*GKV	5-P-1493-4X	5-P-1493	45	5-P-1480	31	2-P-946	44
288*MKV	5-P-1493-6X	5-P-1493	45	5-P-1482	35	2-P-948	40
288*PKV	5-P-1493-7X	5-P-1493	45	5-P-1483	37	2-P-950	38
288*SKV	5-P-1493-8X	5-P-1493	45	5-P-1484	39	2-P-952	36
288*TKV	5-P-1493-10X	5-P-1493	45	5-P-1485	42	2-P-954	33

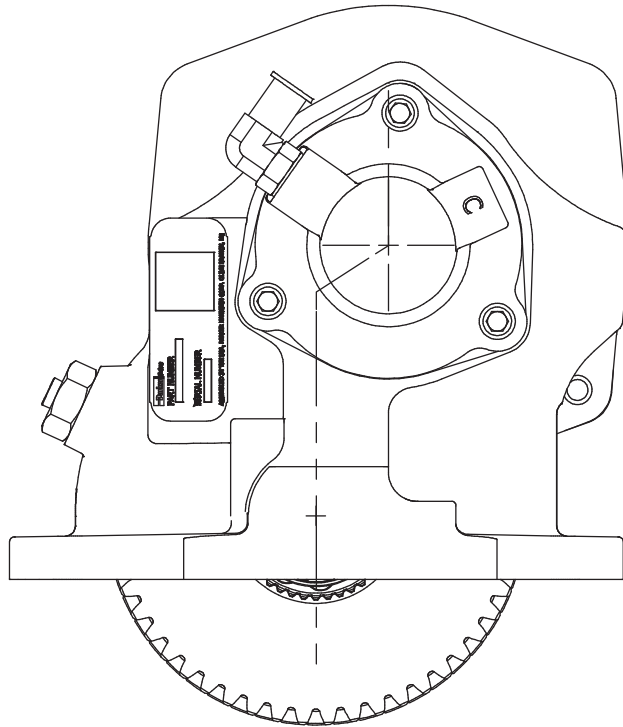

**Lubrication Option P & W Shown**

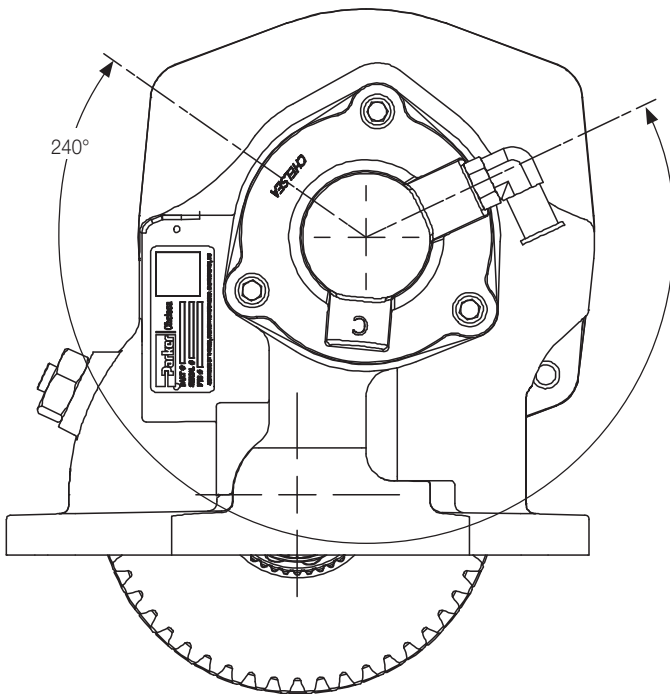

**Lubrication Option S & Y Shown**

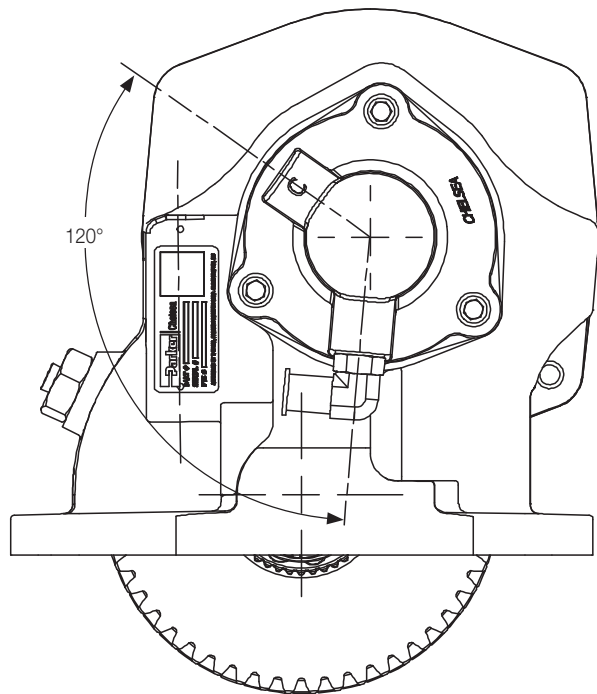

**Lubrication Option R & V Shown**

**Lube Options**

**Pressure Lube (Continued)**

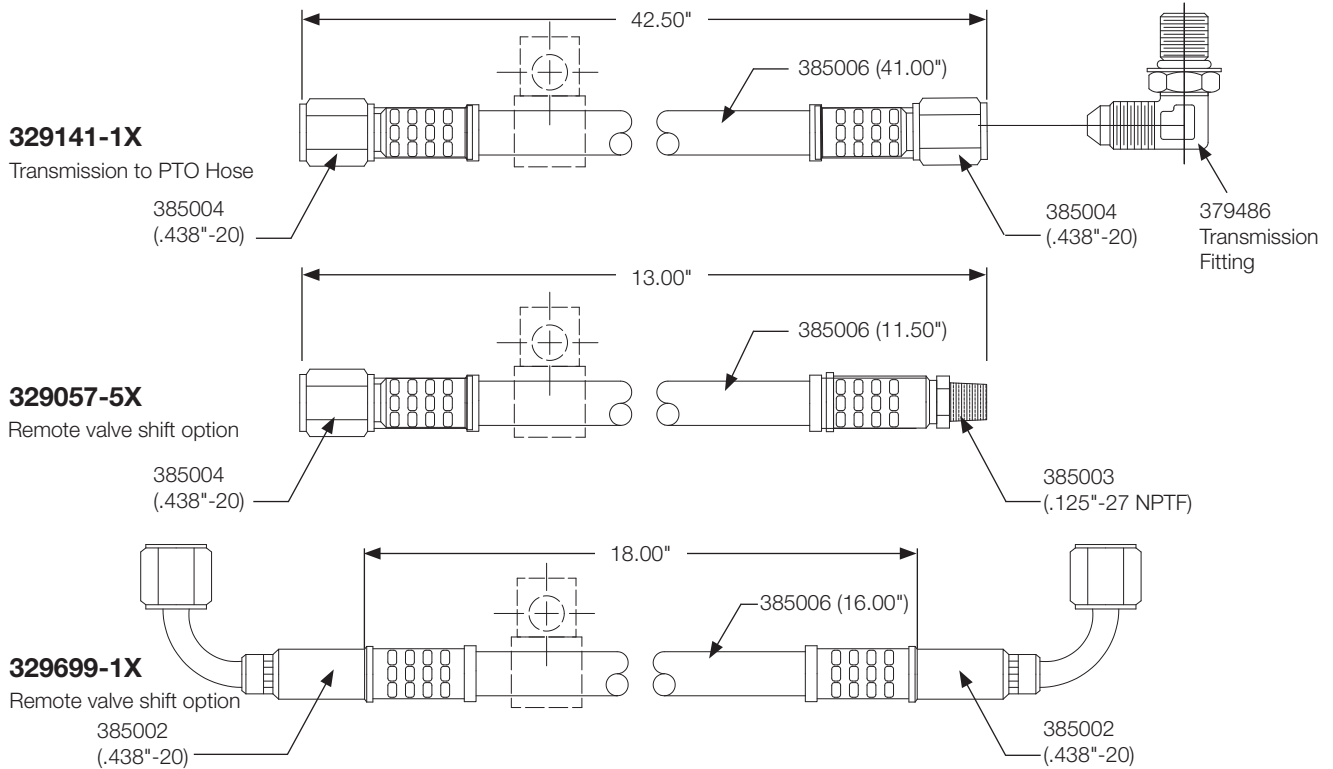

**Wet Spline Installation RB, RF, RK, RS, RY & RZ Output Options**

**(SK-508 Rev B)**

Connect to transmission pressure port.

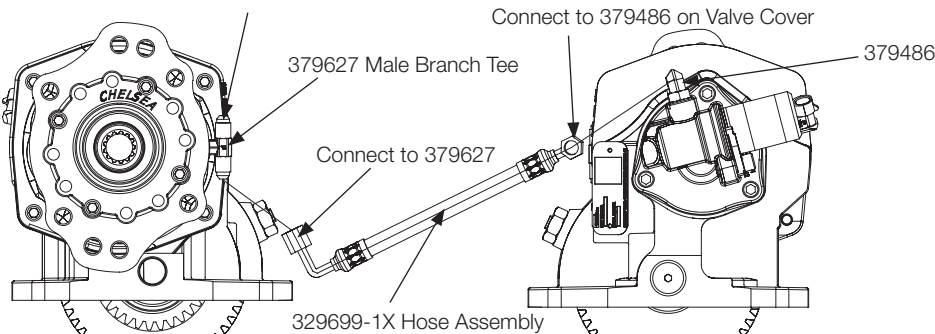

Wet Spline Installation Kits	
Output	Kit Number
RB	329959X
RK	329700X
RF	329700X
RS	329744X
RY	329742X
RZ	329700X

**NOTE:** Not all output options may be available on Series listed above

**Wet Spline Gasket or O-ring**

- RB 35-P-104
- RF/RK/RZ 35-P-102
- RS 28-P-245
- RY 35-P-111

**Flange**

- RB 21-P-894
- RF/RK/RZ 21-P-731
- RS 21-P-769
- RY 21-P-771

35-P-101 Gasket

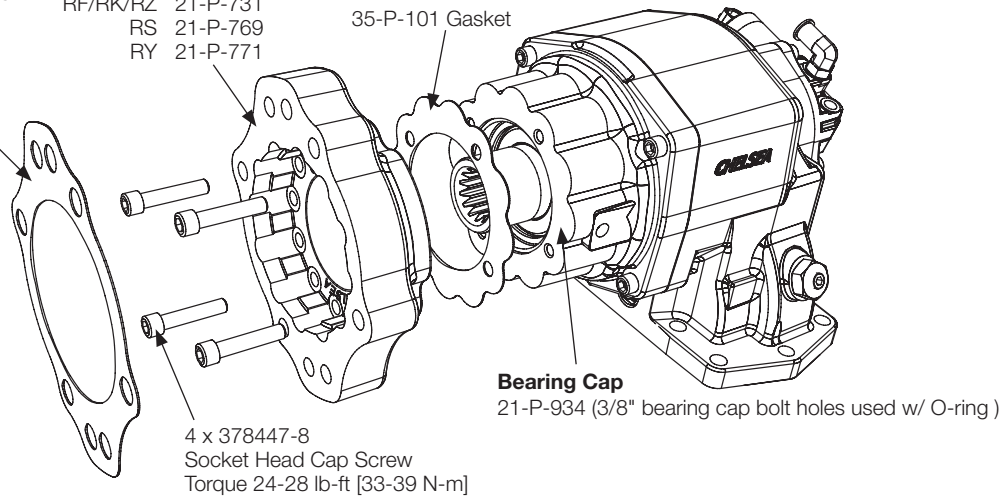

**Housing Dimensions**

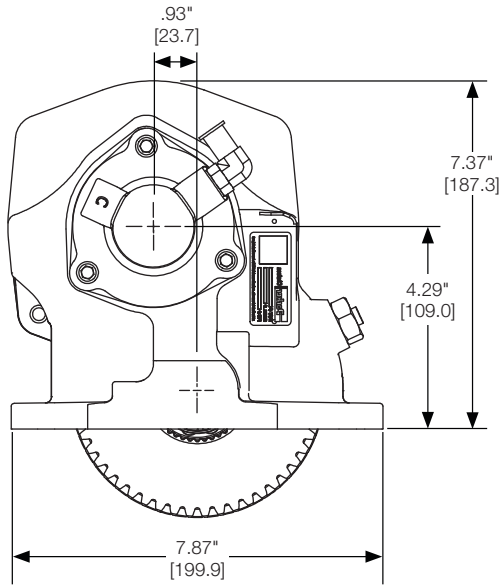

**Assembly 3**

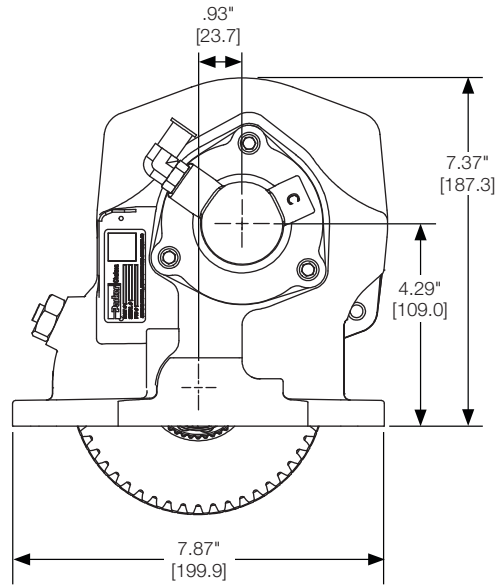

**Assembly 5**

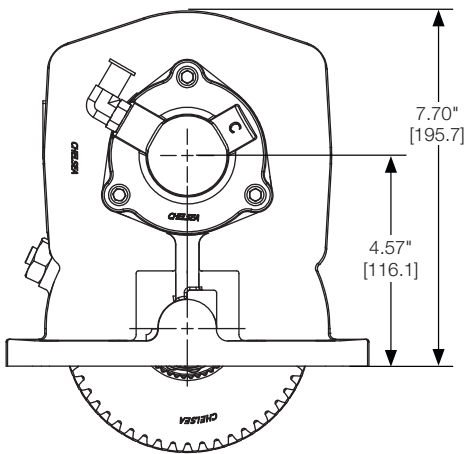

**Assembly 8**

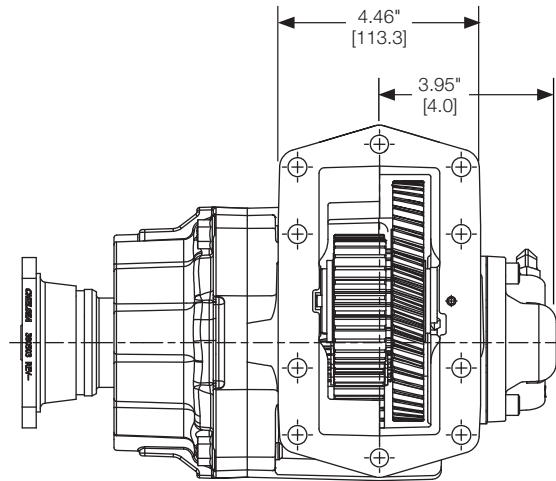

Output Options

Direct Mount Pump Flange & Shaft Dimensions

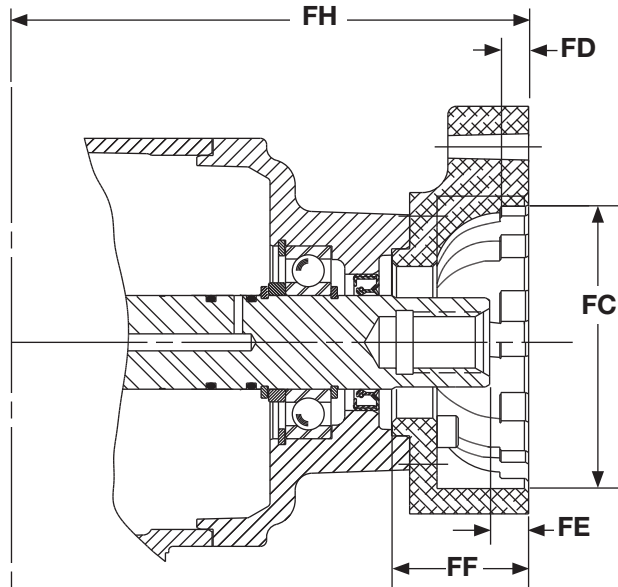

Direct Mount

Pump Flange Suffix	Bolt Circle Diameter	Bolt Holes		FC	FD	FE	FF	FH	Output Shaft
		Hole Diameter	No. Equally Spaced	Female Pilot of Flange	Pilot Depth Hole	Face to End of PTO	Face Thru	Face to Center	Dimensions
RB●	5.000"	1/2"-13 UNC	4	4.000"	.406"	.500"	1.872"	7.643"	7/8" - 13T Spline
RF●	5.750" 5.000"	1/2"-13 UNC	2■ 4	4.000"	.406"	.610"	2.080"	7.670"	1" - 15T Spline
RK●	5.750" 5.000"	1/2"-13 UNC	2/2 4	4.000"	.406"	.500"	1.872"	7.670"	7/8" - 13T Spline
RS●	7.125" 6.375"	5/8"-11 UNC 1/2"-13 UNC	2■ 4	5.003"	.531"	.610"	2.580"	7.670"	1-1/4" - 14T Spline
RY●	4.454"	M12-1.75	4	3.152"	.700"	.549"	2.250"	7.270"	B8x32x36
RZ●	5.750" 5.000"	1/2"-13 UNC	2■ 4	4.000"	.406"	.610"	2.580"	7.670"	1-1/4" - 14T Spline

**CAUTION:** All pump mounting dimensions shown are compiled to conform to SAE/DIN standards; however it shall be the responsibility of the user to determine the correct fit at the time the pump is mounted to the PTO Therefore carefully check the shaft and key or spline engagement.

Companion Flange Mounts & Shaft Dimensions

Pump Flange Suffix	Bolt Circle Diameter	Bolt Holes		FC	FD	FE	FF	FH	Output Shaft
		Hole Diameter	No. Equally Spaced	Female Pilot of Flange	Pilot Depth Hole	Face to End of PTO	Face Thru	Face to Center	Dimensions
AB	3.996"	.404" ▶	8	2.952"	.093" ◆	-	-	8.073"	1-1/2" - 10T Spline
AC	3.307"	.323" ▶	6	2.243"	.080" ◆	-	-	7.950"	1-1/2" - 10T Spline
XD	-	-	-	-	-	-	-	7.090"	1-1/4" Rd Keyed (5/16")
XV	3.750"	-	4	2.751"	.083"	-	-	7.981"	1-1/2" - 10T Spline

- Rotatable Flange Rotates in 30° Increments
- Two Set of Holes Spaced 14° Apart
- ▶ Not Tapped
- ◆ Pilot is Not a Hole

**CAUTION:** All pump mounting dimensions shown are compiled to conform to SAE/DIN standards; however it shall be the responsibility of the user to determine the correct fit at the time the pump is mounted to the PTO Therefore carefully check the shaft and key or spline engagement.



**Output Options**

**Bill of Materials – Driveline Output**

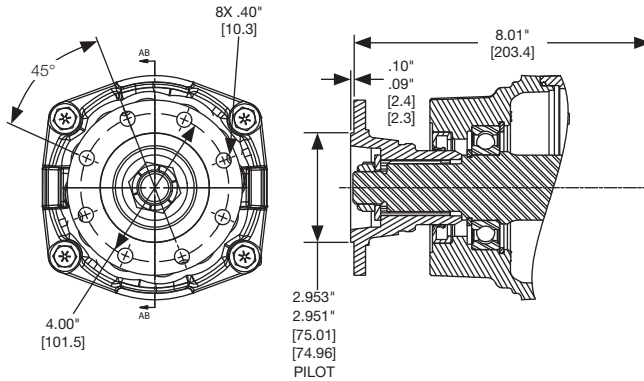

AB Output Option DIN 120 Flange		
Part Number	Description	Qty.
21-P-932	Bearing Cap .....	1
28-P-211	Oil Seal (3.001" x 2.000" x .375").....	1
379558	DIN 120 Companion Flange .....	1
380486	Thin Nylon Lock Nut (.875"-14).....	1
3-P-1068	10T Straight Output Shaft.....	1
380076-13	Hardened Flat Washer (.950" x 1.762" x .157").....	1

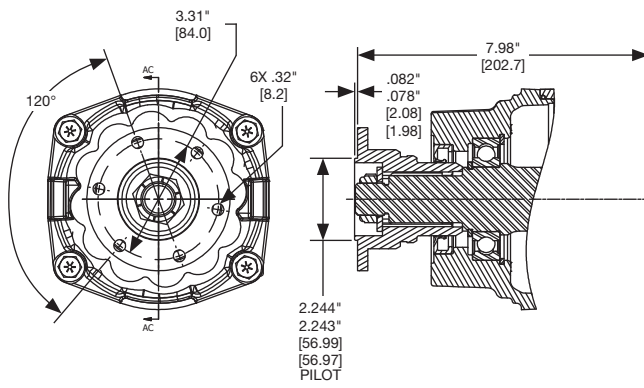

AC Output Option DIN 100 Flange		
Part Number	Description	Qty.
21-P-932	Bearing Cap .....	1
28-P-211	Oil Seal (3.001" x 2.000" x .375").....	1
379742	DIN 100 Companion Flange .....	1
380486	Thin Nylon Lock Nut (.875"-14).....	1
3-P-1068	10T Straight Output Shaft.....	1
380076-13	Hardened Flat Washer (.950" x 1.762" x .157").....	1

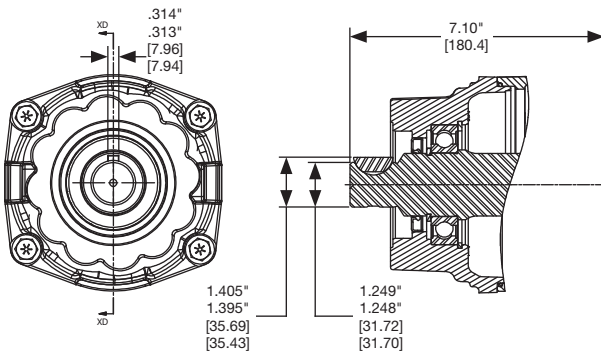

XD Output Option Rd Standard Shaft (1-1/4" w/ 5/16" Key)		
Part Number	Description	Qty.
21-P-932	Bearing Cap .....	1
28-P-267	Oil Seal (2.627" x 1.750" x .312").....	1
3-P-1154	Output Shaft.....	1
500007-29	Woodruff Key.....	1

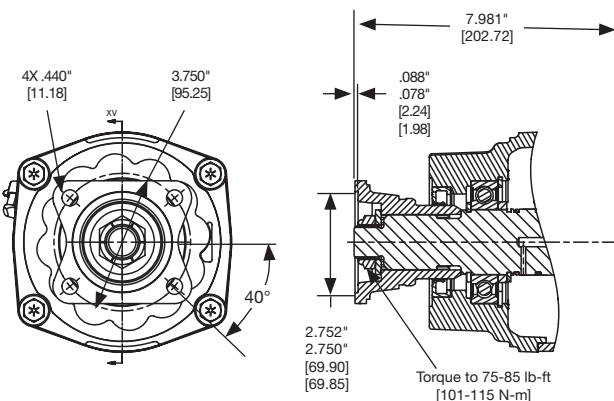

XV Output Option 1410 Series Companion Flange		
Part Number	Description	Qty.
3-P-1068	Output Shaft 10T Straight.....	1
380563-28	Bearing Cap Bolts .....	1
21-P-932	Bearing Cap .....	1
28-P-211	Oil Seal (3.001" x 2.000" x .375").....	1
380503	1410 Series Companion Flange.....	1
380076-13	Washer (.950" x 1.762" x .157").....	1
380486	Thin Nylon Lock Nut (.875"-14).....	1



**Bill of Materials — Pump Mount**

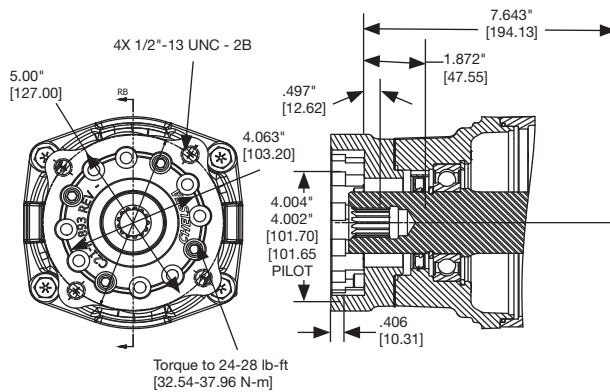

RB Output Option		
Rotatable SAE B 4-Bolt Flange, SAE B Shaft (7/8" - 13T)		
Part Number	Description	Qty.
3-P-1155	Output Shaft.....	1
21-P-933	Bearing Cap .....	1 or
21-P-934	Bearing Cap (Wet Spline Only).....	1
328170-216X	Cap Screw Bag Kit .....	1
35-P-101	Rotatable Flange Gasket (Wet Spline) (Ships w/ Kit).....	1
21-P-894	Pump Flange (Ships Loose w/ Unit) .....	4
	<b>Wet Spline LOOSE PARTS</b> .....	1
329699-1X	Hose Assembly .....	1
329959X	Wet Spline Loose Parts Kit .....	1
329658X	Cover Kit .....	1

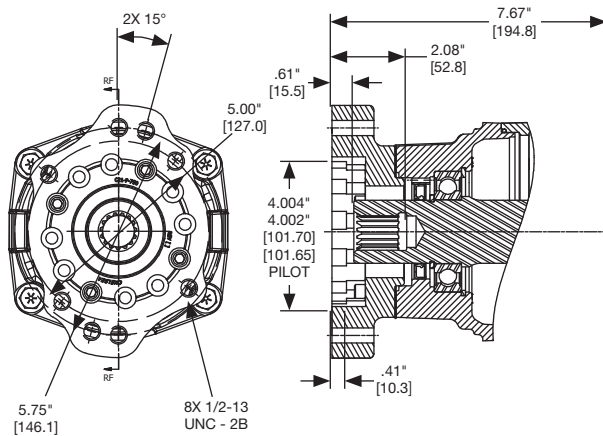

RF Output Option		
Rotatable SAE B 2 & 4-Bolt Flange, SAE BB Shaft (1" - 15T)		
Part Number	Description	Qty.
35-P-101	Wet Spline Bearing Cap Gasket (Ships w/ Kit) .....	1
21-P-933	Bearing Cap .....	1 or
21-P-934	Bearing Cap (Wet Spline Only).....	1
28-P-267	Oil Seal (2.627" x 1.750" x .312").....	1
3-P-1099	Output Shaft (1" - 15T) .....	1
21-P-731	Pump Flange (Ship Loose w/ Unit).....	1
328170-216X	Cap Screw Bag Kit (378447-8 Qty. 4) .....	1
69-P-18	Tag (Wet Spline Only).....	1
	<b>WET SPLINE LOOSE PARTS</b> .....	
329700X	Wet Spline Loose Parts Kit.....	1
329699-1X	Hose Assembly .....	1
329658X	Cover Kit .....	1

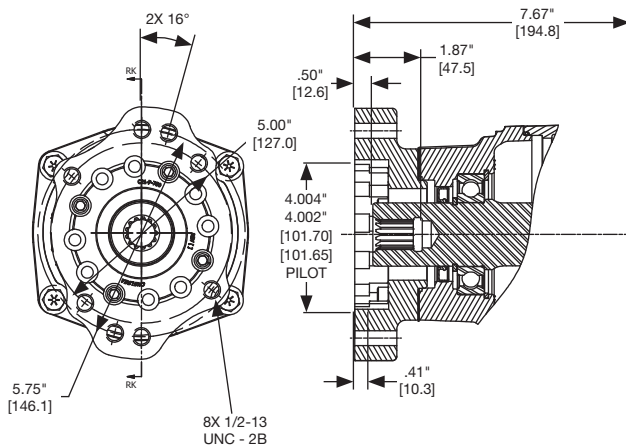

RK Output Option		
Rotatable SAE B 2 & 4-Bolt Flange, SAE B Shaft (7/8" - 13T)		
Part Number	Description	Qty.
35-P-101	Wet Spline Bearing Cap Gasket (Ships w/ Kit) .....	1
21-P-933	Bearing Cap .....	1 or
21-P-934	Bearing Cap (Wet Spline Only).....	1
28-P-267	Oil Seal (2.627" x 1.750" x .312").....	1
3-P-1155	Output Shaft.....	1
21-P-731	Pump Flange (Ship Loose w/ Unit).....	1
328170-216X	Cap Screw Bag Kit (378447-8 Qty. 4) .....	1
69-P-18	Tag (Wet Spline Only).....	1
	<b>WET SPLINE LOOSE PARTS</b> .....	
329700X	Wet Spline Loose Parts Kit.....	1
329699-1X	Hose Assembly .....	1
329658X	Cover Kit .....	1

Output Options

Bill of Materials – Pump Mount (Continued)

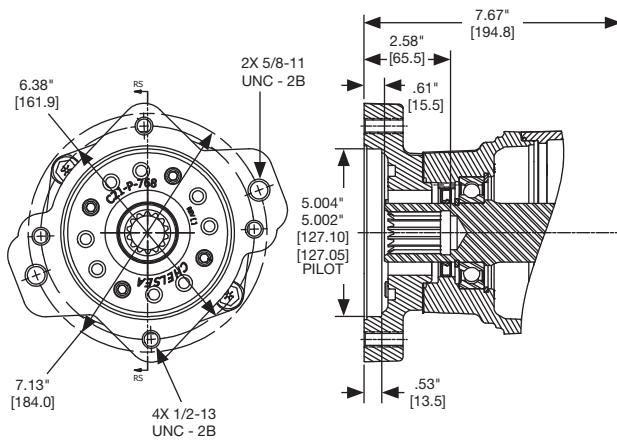

RS Output Option		
Rotatable SAE C 2 & 4-Bolt Flange, SAE Shaft (1-1/4" - 14T)		
Part Number	Description	Qty.
35-P-101	Wet Spline Bearing Cap Gasket (Ships w/ Kit) .....	1
21-P-933	Bearing Cap .....	1 or
21-P-934	Bearing Cap (Wet Spline Only) .....	1
28-P-267	Oil Seal (2.627" x 1.750" x .312") .....	1
3-P-1070	Output Shaft (1-1/4" - 14T) .....	1
21-P-769	Pump Flange (Ship Loose w/ Unit) .....	1
328170-216X	Cap Screw Bag Kit (378447-8 Qty. 4) .....	1
69-P-18	Tag (Wet Spline Only) .....	1
<b>WET SPLINE LOOSE PARTS</b>		
329744X	Wet Spline Loose Parts Kit .....	1
329699-1X	Hose Assembly .....	1
329654X	Cover Kit .....	1

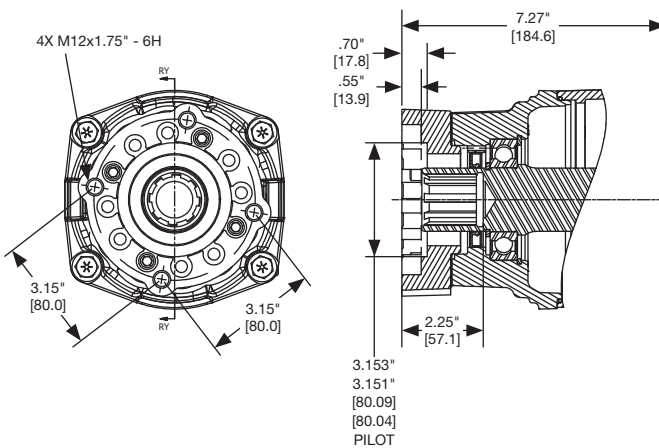

RY Output Option		
Rotatable DIN 5462 Pump Mounting, DIN 5462 Shaft (B8x32x36)		
Part Number	Description	Qty.
35-P-101	Wet Spline Bearing Cap Gasket (Ships w/ Kit) .....	1
21-P-933	Bearing Cap .....	1 or
21-P-934	Bearing Cap (Wet Spline Only) .....	1
28-P-267	Oil Seal (2.627" x 1.750" x .312") .....	1
3-P-1071	Output Shaft DIN 8T .....	1
21-P-771	Pump Flange (Ship Loose w/ Unit) .....	1
328170-216X	Cap Screw Bag Kit (378447-8 Qty. 4) .....	1
69-P-18	Tag (Wet Spline Only) .....	1
<b>WET SPLINE LOOSE PARTS</b>		
329742X	Wet Spline Loose Parts Kit .....	1
329699-1X	Hose Assembly .....	1
329659X	Cover Kit .....	1

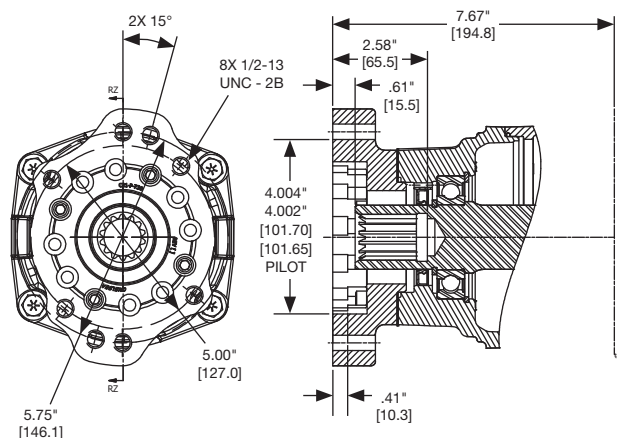

RZ Output Option		
Rotatable SAE B 2 & 4-Bolt Flange, SAE C Shaft (1-1/4" - 14T)		
Part Number	Description	Qty.
35-P-101	Wet Spline Bearing Cap Gasket (Ships w/ Kit) .....	1
21-P-933	Bearing Cap .....	1 or
21-P-934	Bearing Cap (Wet Spline Only) .....	1
28-P-267	Oil Seal (2.627" x 1.750" x .312") .....	1
3-P-1070	Output Shaft (1-1/4" - 14T) .....	1
21-P-731	Pump Flange (Ship Loose w/ Unit) .....	1
328170-216X	Cap Screw Bag Kit (378447-8 Qty. 4) .....	1
69-P-18	Tag (Wet Spline Only) .....	1
<b>WET SPLINE LOOSE PARTS</b>		
329700X	Wet Spline Loose Parts Kit .....	1
329699-1X	Hose Assembly .....	1
329658X	Cover Kit .....	1

**Pressure Port Locations & Hose Chart**

**(SK-414 Rev A)**

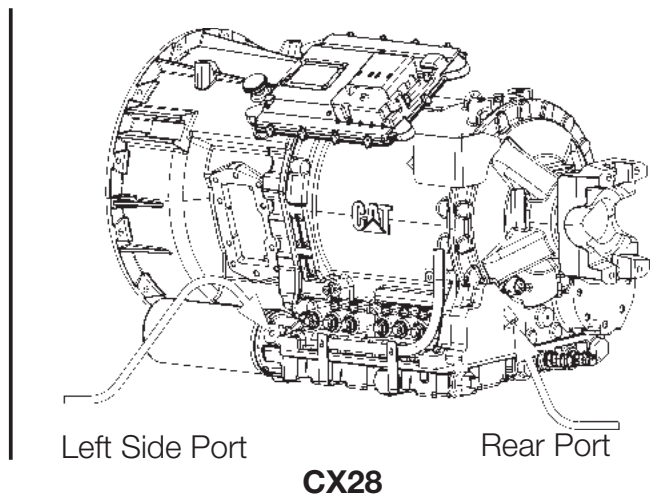
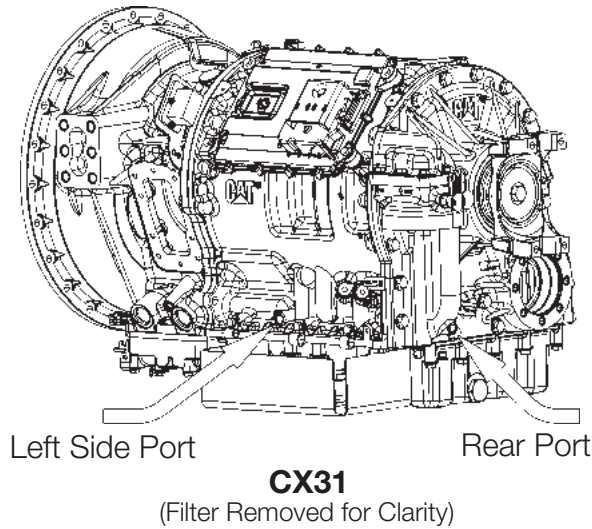

**Both High Pressure Connections are -4 O-ring Boss**

HOSE CHART								
Trans.	PTO	PTO Location	High Oil Pressure Location	PTO Valve Location	PTO Fitting	Trans. Fitting	Trans.-PTO Valve Hose #	
CX31 CX28	288	Driver (LHS)	LHS	Attached	379486	379812	329075-1X	
		Driver (LHS)	Rear				329075-5X	
		Pass. (RHS)	LHS				329075-2X	
		Pass. (RHS)	Rear				329075-5X	
		Driver (LHS)	LHS	Remote		379486	379812	329130-6X
		Driver (LHS)	Rear					329130-6X
		Pass. (RHS)	LHS					329130-6X
		Pass. (RHS)	Rear					329130-6X

LHS = Left Hand Side of Transmission, 8 O'clock position  
 RHS = Right Hand Side of Transmission, 1 O'clock position

**NOTES:**

- One PTO Fitting 379486 and one transmission fitting 379812 are included with the PTO unit.  
If using 379486 in transmission it must be purchased separately.
- 379486 elbow will not install on left hand (driver) side oil port due to transmission interference.
- If 379486 is listed as transmission fitting for rear location, route hose along right hand (passenger) side of transmission and under transmission output yoke.

Part Number	Description	Qty.	Part Number	Description	Qty.
<b>SERVICE KITS</b>			<b>SERVICE KITS (continued)</b>		
<b>329071-63X</b>	<b>Bearing Kit (All Outputs Except BD &amp; BV) (281 Series)</b>		<b>329071-80X</b>	<b>Gasket &amp; Seal Kit (All Outputs Except BV &amp; BD) (281/288 Series)</b>	
379746	Lockring .....	1	28-P-211	Oil Seal (3.001" x 2.000" x .375").....	1
378263	Internal Lockring .....	1	28-P-285	O-ring (1.597" x .103").....	2
379555	Lockring .....	1	28-P-119	Oil Seal (1.379" x .875" x .250").....	1
560972	Needle Roller Bearing Assembly (1.500" x 1.875" x 1.000") .....	2	28-P-178	O-ring (4.359" x .138").....	1
550311	Ball Bearing (1.770" x 3.346" x .748").....	1	35-P-101	Bearing Cap Gasket (Wet Spline).....	1
550439	Tapered Cone Bearing (.750" x .859").....	2	28-P-191	O-ring (.549" x .103").....	1
31-P-102	Thrust Washer (.754" x .440" x .030").....	1	28-P-267	Oil Seal (2.627" x 1.750" x .312").....	1
14-P-73-1	Spacer (.762" x 1.500" x .150") .....	1	22-P-151	Shim Gasket.....	1
14-P-73-2	Spacer (.762" x 1.500" x .153") .....	1	22-P-112	Valve Cap Gasket .....	1
14-P-73-3	Spacer (.762" x 1.500" x .156") .....	1	35-P-74	Shim Gasket .....	1
561088	Needle Roller Bearing Assembly (1.500" x 1.875" x 1.250") .....	1	28-P-329	O-ring (5.487" x .103").....	1
<b>329071-64X</b>	<b>Bearing Kit (BD &amp; BV Outputs) (281 Series)</b>		<b>329071-82X</b>	<b>Gasket &amp; Seal Kit (BV, BD) (281 Series)</b>	
379746	Lockring .....	1	28-P-225	Oil Seal (2.004" x 1.375" x .315").....	1
378263	Lockring .....	1	28-P-244	O-ring (1.174" x .103").....	4
379555	Lockring .....	1	22-P-151	Shim Gasket.....	2
378895	Lockring .....	1	22-P-112	Valve Cap Gasket .....	1
378576	Lockring .....	1	28-P-212	Oil Seal (2.506" x 1.750" x .315").....	1
550010	Ball Bearing (1.378" x 2.834" x .669").....	1	28-P-191	O-ring (.549" x .103").....	1
560972	Needle Roller Bearing Assembly (1.500" x 1.875" x 1.000") .....	2	28-P-252	Brake O-ring (2.674" x .103").....	1
550439	Tapered Cone Bearing (.750" x .859").....	2	28-P-178	O-ring (4.359" x .138").....	1
31-P-102	Thrust Washer (.754" x .440" x .030").....	1	28-P-119	Oil Seal (1.379" x .875" x .250").....	1
14-P-73-1	Spacer (.762" x 1.500" x .150") .....	1	28-P-329	O-ring (5.487" x .103").....	1
14-P-73-2	Spacer (.762" x 1.500" x .153") .....	1	<b>330154X</b>	<b>Gasket &amp; Clutch Plates Kit (281 Series)</b>	
14-P-73-3	Spacer (.762" x 1.500" x .156") .....	1	2-P-1038	Inner Gear Clutch 36T .....	1
<b>329071-66X</b>	<b>Bearing Kit (288 Series)</b>		379485	Friction Disc.....	8
378263	Lockring .....	1	379595	Clutch Plate.....	7
379555	Lockring .....	1	<b>329071-83X</b>	<b>Solenoid Valve Seal Kit (281 Series)</b>	
560972	Needle Roller Bearing Assembly (1.500" x 1.875" x 1.000") .....	1	2016V-7	O-ring (.614" x .070").....	1
550311	Ball Bearing (1.770" x 3.346" x .748").....	1	2017V-7	O-ring (.676" x .070").....	1
550439	Tapered Cone Bearing (.750" x .859").....	2	2020V-7	O-ring (.864" x .070").....	2
31-P-102	Thrust Washer (.754" x .440" x .030").....	1			
14-P-73-1	Spacer (.762" x 1.500" x .150") .....	1			
14-P-73-2	Spacer (.762" x 1.500" x .153") .....	1			
14-P-73-3	Spacer (.762" x 1.500" x .156") .....	1			
379668	Lockring .....	2			

Continued on Next Page

BOMs in each kit group are listed in order based on part number.

**Kits Bill of Materials**

Part Number	Description	Qty.	Part Number	Description	Qty.
<b>STUD KITS</b>			<b>INSTALLATION INSTRUCTION KITS</b>		
<b>7170-86X</b>	<b>Mounting Kit (FJ Input Option, 3 &amp; 5 Arr.) (281, 288 Series)</b>		<b>328948-9X</b>	<b>Gasket &amp; Installation Instructions Kit (281, 288 Series)</b>	
379451	Pilot Screw (M10-1.5 x .984") .....	2	328946X	Caution Label Kit .....	2
379453-10	Cap Screw (FC) (M10-1.5 x 1.378") .....	8	35-P-74	Shim Gasket.....	8
379486	90° Elbow (.438"-20) .....	1	379085-2	Instructions Label .....	1
SK-355	Installation Card Mounting Kit .....	1	379624	Product Warranty Card.....	1
<b>7170-107X</b>	<b>Mounting Kit (FJ Input Option, 8 Arr.) (281, 288 Series)</b>		Owner's Manual	HY25-1380-M1/US .....	1
379486	90° Elbow (.438"-20) .....	1	Safety Guide	HY25-1002-M1/US .....	1
379453-10	Cap Screw (M10-1.5 x 1.378") .....	8			
379453-8	Cap Screw (M10-1.5 x 1.181") .....	2			
379451	Pilot Screw (M10-1.5 x .984") .....	2			
SK-355	Installation Card Mounting Kit .....	1			
<b>7170-117X</b>	<b>Mounting Kit (KV Input Option, 3 &amp; 5 Arr.) (281, 288 Series)</b>				
379451	Pilot Screw (M10-1.5 x .984") .....	2			
379453-10	Cap Screw (M10-1.5 x 1.984") .....	8			
379812	Male Connector (.438"-20) .....	1			
<b>7170-118X</b>	<b>Mounting Kit (KV Input Option, 8 Arr.) (281, 288 Series)</b>				
379451	Pilot Screw (M10-1.5 x .984") .....	2			
379453-8	Ferry Head Cap Screw (M10-1.5 x 1.181") .....	1			
379453-10	Cap Screw (M10-1.5 x 1.378") .....	8			
SK-355	Installation .....	1			
379812	Male Connector.....	1			

Continued on Next Page

BOMs in each kit group are listed in order based on part number.



Part Number	Description	Qty.	Part Number	Description	Qty.
<b>HYDRAULIC INSTALLATION KITS</b>			<b>HYDRAULIC INSTALLATION KITS (Continued)</b>		
<b>329024-12X</b>	<b>12VDC Installation Kit (FJ Input Option, B Shift) (281 Series)</b>		<b>329237-12X</b>	<b>12VDC Remote Valve Kit (FJ Input Option, G Shift) (281 Series)</b>	
380672	Female Spade Connector (.250").....	3	329231X	Valve Connector & Wire .....	1
380668X	Bracket & Label Assembly .....	1	75-P-45-12	12VDC Electrical Rocker Switch .....	1
379061	Plastic Wire Tie.....	6	379131-1	Pipe Reducer Bushing (.125"-27 x .250"-18).....	1
379252	Electrical Butt Connector .....	1	379257	Electrical Speed Limiter Connector .....	2
379257	Electrical Connector .....	2	379252	Electrical Speed Limiter Butt Connector.....	1
379265	Grommet.....	1	379258	Mounting Bracket .....	1
75-P-45-12	12VDC Electrical Light Rocker Switch .....	1	379265	Grommet w/ Speed Control.....	1
SK-347	Installation Sketch .....	1	380672	Female Spade Connector (.250").....	3
379502	Pressure Switch.....	1	380668X	Bracket & Label Assembly .....	1
379504	Electrical Valve Connector .....	1	379449	Male Connector (.438"-20 x .250"-18).....	1
379900	Fuse Holder Assembly.....	1	379502	Pressure Switch.....	1
379254-17	14G Electrical Fork Wire .....	1	379686-1	12VDC Hydraulic Shift Solenoid Valve.....	1
<b>329024-24X</b>	<b>24VDC Installation Kit (FJ Input Option, D Shift) (281 Series)</b>		379700	Swivel Nut Tee (.438"-20) .....	1
75-P-45-24	24VDC Electrical Rocker Switch .....	1	379711	Tee (.375"-24 x .438"-20 x .438"-20).....	1
379252	Electrical Butt Connector .....	1	379900	Fuse Holder.....	1
379257	Electrical Speed Limiter Connector .....	2	380010	Female SAE Swivel Nut Union (.438"-20)....	1
379265	Grommet.....	1	500357-7	Lock Washer (.194" x .337" x .047").....	2
380672	Female Spade Connector (.250").....	3	500457-6	Round Head Slotted Screw (.190"-32 x .438") .....	2
380668X	Bracket & Label Assembly .....	1	SK-432	Remote Valve Installation Sketch .....	1
379502	Pressure Switch.....	1	379254-17	14G Electrical Fork Terminal .....	1
379900	Fuse Holder Assembly.....	1	75-P-46X	Wire & Connectors Kit .....	1
379504	Electrical Valve Connector .....	1	<b>329237-24X</b>	<b>24VDC Remote Valve Installation Kit (FJ Input Option, H Shift) (281 Series)</b>	
379254-17	14G Electrical Fork Wire .....	1	329231X	Valve Connector & Wire .....	1
379061	Plastic Wire Tie.....	6	75-P-45-24	24VDC Electrical Rocker Switch .....	1
SK-347	Hydraulic Shift Installation Sketch .....	1	379131-1	Pipe Reducer Bushing (.125"-27 x .250"-18).....	1
			379252	Electrical Speed Limiter Butt Connector.....	1
			379257	Electrical Speed Limiter Connector .....	2
			379258	Mounting Bracket .....	1
			379265	Grommet w/ Speed Control.....	1
			380672	Female Spade Connector (.250").....	3
			380668X	Bracket & Label Assembly .....	1
			379449	Male Connector (.438"-20 x .250"-18).....	1
			379502	Pressure Switch.....	1
			379686-2	24VDC Hydraulic Shift Solenoid Valve.....	1
			379700	Swivel Nut Tee (.438"-20) .....	1
			379711	Tee (.375"-24 x .438"-20 x .438"-20).....	1
			379900	Fuse Holder.....	1
			380010	Female SAE Swivel Nut Union (.438"-20)....	1
			500357-7	Lock Washer (.194" x .337" x .047").....	2
			500457-6	Round Head Slotted Screw (.190"-32 x .438") .....	2
			SK-432	Remote Valve Installation Sketch .....	1
			379254-17	14G Electrical Fork Wire .....	1
			75-P-46X	Wire & Connectors Kit .....	1

Continued on Next Page

BOMs in each kit group are listed in order based on part number.

**Kits Bill of Materials**

Part Number	Description	Qty.	Part Number	Description	Qty.
<b>HYDRAULIC INSTALLATION KITS (Continued)</b>			<b>HYDRAULIC INSTALLATION KITS (Continued)</b>		
<b>329443-12X</b>	<b>12VDC Installation Kit (KV Input Option, B Shift) (281 Series)</b>		<b>329445-24X</b>	<b>24VDC Remote Valve Installation Kit (KV Input Option, H Shift) (281 Series)</b>	
378881	Rocker Switch .....	1	329446-24X	24VDC Remote Mount Valve Assembly .....	1
378978	12VDC Indicator Light .....	1	378881	Rocker Switch .....	1
379061X	Plastic Wire Tie.....	1	379005	24VDC Indicator Light .....	1
379252	Electrical Butt Connector .....	1	379252	Electrical Butt Connector .....	1
379257	Electrical Connector .....	1	379257	Electrical Connector .....	1
379265	Grommet.....	1	379265	Grommet.....	1
379306	Electrical Fork Terminal .....	3	379306	Electrical Fork Terminal .....	3
379336	Electrical/Air Shifter Switch Bracket .....	1	379336	Electrical/Air Switch Bracket.....	1
379502	Pressure Switch.....	1	379502	Pressure Switch .....	1
379928	Valve & Wire Connector .....	1	379812	Male Connector (.438"-20) .....	3
379900	Fuse Holder Assembly .....	1	379900	Fuse Holder Assembly.....	1
<b>329443-24X</b>	<b>24VDC Installation Kit (KV Input Option, D Shift) (281 Series)</b>		379928	Valve & Wire Connector .....	1
378881	Rocker Switch .....	1	380010	Female SAE Swivel Nut Union (.438"-20)....	1
379005	24VDC Indicator Light .....	1	379700	Swivel Nut Tee (.438"-20) .....	1
379061X	Plastic Wire Tie.....	1	379711	Tee (.375"-24 x .438"-20 x .438"-20).....	1
379252	Electrical Butt Connector .....	1	<b>329650X</b>	<b>Electronic Overspeed Control (K &amp; L Shift) (281 Series)</b>	
379257	Electrical Connector .....	1	328923-10X	Speed Sensor Cable - 10 ft .....	1
379265	Grommet.....	1		(.250"-20) NC Hex Bolt x 1" Lg.....	2
379306	Electrical Fork Terminal .....	3		(.250") Flat Washer .....	2
379336	Electrical/Air Shifter Switch Bracket .....	1		(.250") Lock Washer .....	2
379502	Pressure Switch.....	1		(.250") Hex Nut .....	2
379928	Valve & Wire Connector .....	1	Owner's Manual	HY25-1650-M1/US .....	1
379900	Fuse Holder Assembly .....	1	20071-3	EOC Unit (NSS) .....	1
<b>329444X</b>	<b>12VDC &amp; 24VDC Installation Kit w/ EOC (KV Input Option, K &amp; L Shift) (281 Series)</b>		<b>329076X</b>	<b>12VDC &amp; 24VDC Installation Kit w/ EOC (FJ Input Option, K &amp; L Shift) (281 Series)</b>	
379061X	Plastic Wire Tie.....	1	379061X	Plastic Wire Tie Assembly.....	1
379252	Electrical Butt Connector .....	1	379252	Electrical Butt Connector.....	1
379257	Electrical Connector .....	1	379257	Electrical Speed Limiter Connector.....	1
379265	Grommet.....	1	379265	Grommet w/ Speed Control.....	1
379502	Pressure Switch.....	1	379502	Pressure Switch.....	1
379928	Valve & Wire Connector .....	1	379504	Valve Connector & Wire .....	1
<b>329445-12X</b>	<b>12VDC Remote Valve Installation Kit (KV Input Option, G Shift) (281 Series)</b>		75-P-46X	Wire & Connectors Kit .....	1
329446-12X	12VDC Remote Mount Valve Assembly .....	1			
378881	Rocker Switch .....	1			
378978	12VDC Indicator Light .....	1			
379252	Electrical Butt Connector .....	1			
379257	Electrical Connector .....	1			
379265	Grommet.....	1			
379306	Electrical Fork Terminal .....	3			
379336	Electrical/Air Switch Bracket .....	1			
379502	Pressure Switch .....	1			
379812	Male Connector (.438"-20) .....	3			
379900	Fuse Holder Assembly.....	1			
379928	Valve & Wire Connector .....	1			
380010	Female SAE Swivel Nut Union (.438"-20)....	1			
379700	Swivel Nut Tee (.438"-20) .....	1			
379711	Tee (.375"-24 x .438"-20 x .438"-20).....	1			

Continued on Next Page

BOMs in each kit group are listed in order based on part number.

Part Number	Description	Qty.	Part Number	Description	Qty.
<b>AIR INSTALLATION KITS</b>			<b>SHIFTER CONVERSION KITS</b>		
<b>328388-85X</b>	<b>Installation Kit Air Shift (S Shift) (281 Series)</b>		<b>329175-12X</b>	<b>12VDC EOC Conversion Kit (FJ Input Option) (281 Series)</b>	
SK-427	Installation Sketch .....	1	28-P-171	O-ring (.644" x .087").....	1
329214X	Air Shifter Valve S Shifter Assembly.....	1	329650X	12VDC Speed Limiter Assembly .....	1
378414	Air Shifter Pressure Protection Valve .....	1	329076X	12VDC & 24VDC Installation Kit w/ EOC.....	1
378416	Hex Nipple (.250"-18) .....	1	379243	Speed Sensor .....	1
379042	Male Connector (.250" Tube to .125"-27 Pipe) .....	3	<b>329175-24X</b>	<b>24VDC EOC Conversion Kit (FJ Input Option) (281 Series)</b>	
379044-6	Tubing (.253" x .179" x 30 ft) .....	1	28-P-171	O-ring (.644" x .087").....	1
379061	Plastic Wire Tie.....	6	329650X	24VDC Speed Limiter Assembly .....	1
379252	Electrical Butt Connector.....	1	329076X	12VDC & 24VDC w/ EOC Installation Kit.....	1
379257	Electrical Speed Limiter Connector.....	2	379243	Speed Sensor .....	1
379265	Grommet w/ Speed Control.....	1	<b>329354-12X</b>	<b>12VDC Remote Valve Conversion Kit (281 Series)</b>	
379502	Pressure Switch.....	1	22-P-112	Valve Cap Gasket .....	1
379504	Electrical Valve Connector .....	1	329230X	Electrical Wire & Butt Connector.....	1
379305	Pressure Switch.....	1	329231X	Valve Connector Wire Assembly .....	1
379254-17X	Blue Wire.....	1	379258	Solenoid Valve Mounting Bracket.....	1
379900	Fuse Holder Assembly .....	1	379449	Male Connector (.438"-20 x .250"-18).....	2
380009	Female Connector .....	1	379686-1	12VDC Hydraulic Shifter Solenoid Valve.....	1
379665-1	Decal S & T Options .....	1	500357-7	Lock Washer (.337" x .190" x .047") .....	2
379306	Electrical Fork Connector.....	3	500457-6	Round Head Slotted Screw (.190"-32 x .438") .....	2
<b>328388-86X</b>	<b>Installation Kit Air Shift (T Shift) (281 Series)</b>		379564-2	Shipping Cap .....	2
SK-427	Installation Sketch .....	1	328075X	Hose Assembly (36") .....	1
329316X	Valve T Shifter Air Shifter.....	1	379700	Swivel Nut Tee (.438"-20) .....	1
378414	Pressure Protection Valve .....	1	380010	Female SAE Swivel Nut Union (.438"-20)....	1
378416	Hex Nipple (.250"-18) .....	1	379486	90° Elbow (.438"-20) .....	1
379042	Male Connector (.250" Tube to .125"-27 Pipe) .....	3	329403X	Seal Cap Assembly .....	1
379044-6	Tubing (.253" x .179" x 30 ft) .....	1	379711	Tee (.375"-24 x .438"-20 x .438"-20).....	1
379061	Plastic Wire Tie.....	6	379131-1	Pipe Reducer Bushing .....	1
379252	Electrical Butt Connector.....	1	SK-432	12VDC Remote Solenoid Installation Kit ....	1
379257	Electrical Speed Limiter Connector.....	2	329057-4X	Hose Assembly (16.75") .....	2
379265	Grommet w/ Speed Control.....	1	<b>329354-24X</b>	<b>24VDC Conversion Kit Remote Valve (281 Series)</b>	
379502	Pressure Switch.....	1	22-P-112	Valve Cap Gasket .....	1
379504	Electrical Valve Connector .....	1	329230X	Electrical Wire & Butt Connector.....	1
379305	Pressure Switch.....	1	329231X	Valve Connector Wire Assembly .....	1
379254-17X	Blue Wire.....	1	379258	Solenoid Valve Mounting Bracket.....	1
379900	Fuse Holder Assembly .....	1	379449	Male Connector (.438"-20 x .250"-18).....	1
380009	Female Connector .....	1	379686-2	24VDC Hydraulic Shifter Solenoid Valve.....	1
379665-1	Decal S & T Options .....	1	500357-7	Lock Washer (.337" x .190" x .047") .....	2
379306	Electrical Fork Connector.....	3	500457-6	Round Head Slotted Screw (.190"-32 x .438") .....	2
			379564-2	Shipping Cap .....	2
			328075X	Hose Assembly (36") .....	1
			379700	Swivel Nut Tee (.438"-20) .....	1
			380010	Female SAE Swivel Nut Union (.438"-20)....	1
			379486	90° Elbow (.438"-20) .....	1
			329403X	Seal Cap Assembly .....	1
			379711	Tee (.375"-24 x .438"-20 x .438"-20).....	1
			379131-1	Pipe Reducer Bushing .....	1
			SK-432	24VDC Remote Solenoid Installation Kit ....	1
			329057-4X	Hose Assembly (16.75") .....	2

Continued on Next Page

BOMs in each kit group are listed in order based on part number.



**Kits Bill of Materials**

Part Number	Description	Qty.	Part Number	Description	Qty.
<b>SHIFTER CONVERSION KITS (Continued)</b>			<b>OUTPUT CONVERSION KITS</b>		
<b>329448-12X</b>	<b>12VDC Conversion Kit w/ EOC (KV Input Option) (281 Series)</b>		<b>329160-119X</b>	<b>Conversion Kit (XD to SD) (281/288 Series)</b>	
28-P-171	O-ring (.644" x .087").....	1	3-P-1156	Output Shaft DIN 6T.....	1
379243	Air Cylinder Cover.....	1	22-P-151	Gasket Shim.....	1
329650X	12VDC Speed Limiter Assembly.....	1	28-P-267	Oil Seal (2.627" x 1.750" x .312").....	1
329444X	12VDC & 24VDC w/ EOC Installation Kit.....	1	28-P-285	O-ring (1.597" x .103").....	2
<b>329448-24X</b>	<b>24VDC Conversion Kit w/ EOC (KV Input Option) (281 Series)</b>		380563-14	Hex Flange Head Cap Screw (.375"-16 x 1.500").....	4
28-P-171	O-ring (.644" x .087").....	1	379555	Lockring.....	2
379243	Air Cylinder Cover.....	1	379746	Lockring.....	1
329650X	24VDC Speed Limiter Assembly.....	1	380069	Lockring.....	1
329444X	12VDC & 24VDC w/ EOC Installation Kit.....	1	500007-29	Woodruff Key.....	1
			28-P-329	O-ring (5.487" x .103").....	1
			<b>329160-120X</b>	<b>Conversion Kit (XD to SV) (281/288 Series)</b>	
			3-P-1161	Output Shaft 10T Straight.....	1
			22-P-151	Gasket Shim.....	1
			28-P-151	Oil Seal (3.001" x 2.000" x .375").....	1
			28-P-285	O-ring (1.597" x .103").....	2
			380563-14	Hex Flange Head Cap Screw (.375"-16 x 1.500").....	2
			379555	Lockring.....	2
			379746	Lockring.....	1
			380069	Lockring.....	1
			380076-13	Hardened Flat Washer (.950" x 1.762" x .157").....	1
			28-P-329	O-ring (5.487" x .103").....	1
			<b>329160-123X</b>	<b>Conversion Kit (XD to BV) (281/288 Series)</b>	
			378576	Lockring.....	2
			378895	Lockring.....	1
			379746	Lockring.....	1
			379977	Spring Pin (.187" x .625").....	1
			380069	Lockring.....	1
			380081	1410 Series Companion Flange.....	1
			550010	Ball Bearing (1.378" x 2.834" x .669").....	1
			21-P-884	Bearing Cap.....	1
			22-P-151	Bearing Cap Gasket.....	2
			23-P-73	Drag Brake Bearing Cap Spacer.....	1
			28-P-212	Oil Seal (2.506" x 1.750" x .315").....	1
			28-P-244	O-ring (1.174" x .103").....	4
			31-P-113	Thrust Washer (1.385" x 3.125" x .125").....	1
			329410X	Brake Assembly.....	1
			378435-7	Hex Head Cap Screw (.625"-11 x 1.250") ..	1
			380563-28	Hex Flange Head Cap Screw (.375"-16 x 3.500").....	4
			328170-216X	Cap Screw Kit.....	1
			37-P-60	Spring (2.531" x 2.130" x .172").....	1
			3-P-1072	Output Shaft 10T Straight.....	1
			4-P-130	Spacer (.640" x 1.620" x .188").....	1
			4-P-186	Spacer (1.385" x 1.750" x .365").....	1
			28-P-329	O-ring (5.487" x .103").....	1

Continued on Next Page

BOMs in each kit group are listed in order based on part number.

Part Number	Description	Qty.
<b>OUTPUT CONVERSION KITS (Continued)</b>		
<b>329160-130X</b>	<b>Conversion Kit (XD to AB) (281 Series)</b>	
379555	Lockring .....	2
379558	DIN 120 .....	1
379746	Lockring .....	1
380069	Lockring .....	1
380486	Thin Nylon Lock Nut (.875"-14).....	1
22-P-151	Bearing Cap Gasket .....	1
28-P-211	Oil Seal (3.001" x 2.000" x .375").....	1
28-P-285	O-ring (1.597" x .103").....	2
380563-14	Hex Flange Head Cap Screw (.375"-16 x 1.500") .....	4
380076-13	Hardened Flat Washer (.950" x 1.762" x .157") .....	1
3-P-1065	Output Shaft 10T Straight.....	1
550311	Ball Bearing (1.770" x 3.346" x .748").....	1
378263	Internal Lockring .....	1
28-P-329	O-ring (5.487" x .103").....	1
<b>329160-131X</b>	<b>Conversion Kit (XD to SB) (281 Series)</b>	
3-P-1161	Output Shaft 10T Straight.....	1
28-P-285	O-ring (1.597" x .103").....	2
379555	Lockring .....	1
380069	Lockring .....	1
28-P-211	Oil Seal (3.001" x 2.000" x .375").....	1
379558	DIN 120 .....	1
380076-13	Hardened Flat Washer (.950" x 1.762" x .157") .....	1
380486	Thin Nylon Lock Nut (.875"-14).....	1
22-P-151	Bearing Cap Gasket .....	1
380563-14	Hex Flange Head Cap Screw (.375"-16 x 1.500") .....	4
379746	Lockring .....	1
28-P-329	O-ring (5.487" x .103").....	1
<b>329160-134X</b>	<b>Conversion Kit (XD to AC) (281 Series)</b>	
379555	Lockring .....	2
379742	DIN 100 .....	1
379746	Lockring .....	1
380069	Lockring .....	1
380486	Thin Nylon Lock Nut (.875"-14).....	1
22-P-151	Bearing Cap Gasket .....	1
28-P-211	Oil Seal (3.001" x 2.000" x .375").....	1
28-P-285	O-ring (1.597" x .103").....	2
380563-14	Hex Flange Head Cap Screw (.375"-16 x 1.500") .....	4
380076-13	Hardened Flat Washer (.950" x 1.762" x .157") .....	1
3-P-1065	Output Shaft 10T Straight.....	1
550311	Ball Bearing (1.770" x 3.346" x .748").....	1
378263	Internal Lockring .....	1
28-P-329	O-ring (5.487" x .103").....	1

Part Number	Description	Qty.
<b>OUTPUT CONVERSION KITS (Continued)</b>		
<b>329160-135X</b>	<b>Conversion Kit (XD to SC) (281 Series)</b>	
3-P-1161	Output Shaft 10T Straight.....	1
28-P-285	O-ring (1.597" x .103").....	2
379555	Lockring .....	2
380069	Lockring .....	1
28-P-211	Oil Seal (3.001" x 2.000" x .375").....	1
379742	DIN 100 .....	1
380076-13	Hardened Flat Washer (.950" x 1.762" x .157") .....	1
380486	Thin Nylon Lock Nut (.875"-14).....	1
22-P-151	Bearing Cap Gasket .....	1
380563-14	Hex Flange Head Cap Screw (.375"-16 x 1.500") .....	4
379746	Lockring .....	1
550311	Ball Bearing (1.770" x 3.346" x .748").....	1
378263	Lockring .....	1
28-P-329	O-ring (5.487" x .103").....	1
<b>329160-136X</b>	<b>Conversion Kit (XD to BD) (281 Series)</b>	
378576	Lockring .....	2
378895	Lockring .....	1
379746	Lockring .....	1
379977	Spring Pin (.187" x .625") .....	1
380069	Lockring .....	1
550010	Ball Bearing (1.378" x 2.834" x .669").....	1
21-P-888	Drag Brake Bearing Cap.....	1
22-P-151	Bearing Cap Gasket .....	2
23-P-73	Drag Brake Bearing Cap Spacer.....	1
28-P-225	Oil Seal (2.004" x 1.375" x .315").....	1
28-P-244	O-ring (1.174" x .103").....	4
31-P-113	Thrust Washer (1.385" x 3.125" x .125").....	1
329410X	Brake Assembly .....	1
380563-28	Hex Flange Head Cap Screw (.375"-16 x 3.500") .....	4
328170-216X	Cap Screw Kit .....	1
37-P-60	Spring (2.531" x 2.130" x .172") .....	1
3-P-1141	Output Shaft (1.250") Keyed.....	1
4-P-186	Spacer (1.385" x 1.750" x .365") .....	1
28-P-329	O-ring (5.487" x .103").....	1

Continued on Next Page

BOMs in each kit group are listed in order based on part number.

**Kits Bill of Materials**

Part Number	Description	Qty.	Part Number	Description	Qty.
<b>OUTPUT CONVERSION KITS (Continued)</b>			<b>OUTPUT CONVERSION KITS (Continued)</b>		
<b>329160-139X</b>	<b>Conversion Kit (XD to XV) (281/288 Series)</b>		<b>329160-155X</b>	<b>Conversion Kit (XD to RK WET) (281/288 Series)</b>	
3-P-1065	Output Shaft 10T Straight.....	1	21-P-934	Bearing Cap .....	1
28-P-285	O-ring (1.597" x .103").....	2	28-P-267	Oil Seal (2.627" x 1.750" x .312").....	1
379555	Lockring .....	2	21-P-731	Pump Flange.....	1
380069	Lockring .....	1	329699-1X	Hose Assembly .....	1
28-P-211	Oil Seal (3.001" x 2.000" x .375").....	1	329700X	Wet Spline Parts Kit.....	1
380076-13	Hardened Flat Washer (.950" x 1.762" x .157") .....	1	329658X	Cover Kit .....	1
380486	Thin Nylon Lock Nut (.875"-14).....	1	3-P-1126	Output Shaft (7/8" - 13T) .....	1
380503	1410 Series Companion Flange.....	1	28-P-285	O-ring (1.597" x .103").....	2
22-P-151	Bearing Cap Gasket .....	1	379555	Lockring .....	2
380563-14	Hex Flange Head Cap Screw (.375"-16 x 1.500") .....	4	380069	Lockring .....	1
379746	Lockring .....	1	28-P-329	O-ring (5.487" x .103").....	1
550311	Ball Bearing (1.770" x 3.346" x .748").....	1	328170-216X	Bag Kit .....	1
378263	Lockring .....	1	380563-14	Hex Flange Head Cap Screw (.375"-16 x .312") .....	4
28-P-329	O-ring (5.487" x .103").....	1	379746	Lockring .....	1
			550311	Ball Bearing (1.770" x 3.346" x .748").....	1
			378263	Internal Lockring.....	1
			69-P-18	Wet Spline Tag .....	1
<b>329160-154X</b>	<b>Conversion Kit (XD to RK DRY) (281/288 Series)</b>		<b>329160-156X</b>	<b>Conversion Kit (XD to RF DRY) (281/288 Series)</b>	
21-P-933	Bearing Cap .....	1	3-P-1127	Output Shaft (1" - 15T) .....	1
28-P-267	Oil Seal (2.627" x 1.750" x .312").....	1	28-P-329	O-ring (5.487" x .103").....	1
21-P-731	Pump Flange.....	1	28-P-267	Oil Seal (2.627" x 1.750" x .312").....	1
3-P-1126	Output Shaft (7/8" - 13T)	1	28-P-285	O-ring (1.597" x .103").....	2
28-P-285	O-ring (1.597" x .103").....	2	328170-216X	Bag Kit .....	1
379555	Lockring .....	2	380563-14	Hex Flange Head Cap Screw (.375"-16 x .312") .....	4
380069	Lockring .....	1	379555	Lockring .....	2
28-P-329	O-ring (5.487" x .103").....	1	379746	Lockring .....	1
328170-216X	Bag Kit .....	1	380069	Lockring .....	1
380563-14	Hex Flange Head Cap Screw (.375"-16 x .312") .....	4	21-P-933	Bearing Cap .....	1
379746	Lockring .....	1	21-P-731	Pump Flange.....	1
379688	Spline Lubricant.....	1	379688	Spline Lubricant.....	1
550311	Ball Bearing (1.770" x 3.346" x .748").....	1	550311	Ball Bearing (1.770" x 3.346" x .748").....	1
378263	Internal Lockring.....	1	378263	Internal Lockring.....	1
			<b>329160-157X</b>	<b>Conversion Kit (XD to RF WET) (281/288 Series)</b>	
			379555	Lockring .....	2
			379746	Lockring .....	1
			380069	Lockring .....	1
			21-P-934	Bearing Cap .....	1
			28-P-329	O-ring (5.487" x .103").....	1
			28-P-267	Oil Seal (2.627" x 1.750" x .312").....	1
			28-P-285	O-ring (1.597" x .103").....	2
			21-P-731	Pump Flange.....	1
			329658X	Cover Kit .....	1
			329699-1X	Hose Assembly .....	1
			329700X	Wet Spline Parts Kit.....	1
			328170-216X	Bag Kit .....	1
			380563-14	Hex Flange Head Cap Screw (.375"-16 x .312") .....	4
			3-P-1127	Output Shaft (1" - 15T) .....	1
			550311	Ball Bearing (1.770" x 3.346" x .748").....	1
			378263	Internal Lockring.....	1
			69-P-18	Wet Spline Tag .....	1

BOMs in each kit group are listed in order based on part number.

Continued on Next Page

**Kits Bill of Materials**

Part Number	Description	Qty.	Part Number	Description	Qty.
<b>OUTPUT CONVERSION KITS (Continued)</b>			<b>OUTPUT CONVERSION KITS (Continued)</b>		
<b>329160-158X</b>	<b>Conversion Kit (XD to RS DRY) (281 Series)</b>		<b>329160-161X</b>	<b>Conversion Kit (XD to RY WET) (281 Series)</b>	
3-P-1066	Output Shaft (1-1/4" - 14T).....	1	379746	Lockring .....	1
28-P-285	O-ring (1.597" x .103").....	2	550311	Ball Bearing (1.770" x 3.346" x .748").....	1
379555	Lockring .....	1	378263	Internal Lockring.....	1
380069	Lockring .....	1	3-P-1067	Output Shaft (DIN 8T) .....	1
21-P-933	Bearing Cap .....	1	21-P-934	Bearing Cap .....	1
28-P-267	Oil Seal (2.627" x 1.750" x .312").....	1	28-P-285	O-ring (1.597" x .103").....	2
328170-216X	Bag Kit .....	1	379555	Lockring .....	2
21-P-769	Pump Flange .....	1	380069	Lockring .....	1
28-P-329	O-ring (5.487" x .103").....	1	28-P-267	Oil Seal (2.627" x 1.750" x .312").....	1
380563-14	Cap Screw Kit .....	4	21-P-771	Pump Flange.....	1
379746	Lockring .....	1	329699-1X	Hose Assembly Overall.....	1
379688	Spline Lubricant.....	1	329742X	Wet Spline Parts Kit.....	1
550311	Ball Bearing (1.770" x 3.346" x .748").....	1	329659X	Conversion Kit XD to RY Wet Spline .....	1
378263	Internal Lockring.....	1	28-P-329	O-ring (5.487" x .103").....	1
			328170-216X	Bag Kit .....	1
			380563-14	Hex Flange Head Cap Screw (.375"-16 x .312") .....	4
<b>329160-159X</b>	<b>Conversion Kit (XD to RS WET) (281 Series)</b>		69-P-18	Wet Spline Tag .....	1
3-P-1066	Output Shaft (1-1/4" - 14T).....	1			
28-P-285	O-ring (1.597" x .103").....	2	<b>32916-162X</b>	<b>Conversion Kit (XD to RZ DRY) (281 Series)</b>	
379555	Lockring .....	1	3-P-1066	Output Shaft (1-1/4" - 14T).....	1
380069	Lockring .....	1	28-P-285	O-ring (1.597" x .103").....	2
21-P-934	Bearing Cap .....	1	379555	Lockring .....	2
28-P-267	Oil Seal (2.627" x 1.750" x .312").....	1	380069	Lockring .....	1
328170-216X	Bag Kit .....	1	21-P-933	Bearing Cap .....	1
21-P-769	Pump Flange.....	1	28-P-267	Oil Seal (2.627" x 1.750" x .312").....	1
329699-1X	Hose Assembly Overall.....	1	21-P-731	Pump Flange.....	1
329744X	Wet Spline Parts Kit.....	1	28-P-329	O-ring (5.487" x .103").....	1
329654X	Cover Kit- XS.....	1	328170-216X	Bag Kit .....	1
28-P-329	O-ring (5.487" x .103").....	1	380563-14	Hex Flange Head Cap Screw (.375"-16 x .312") .....	4
380563-14	Hex Flange Head Cap Screw (.375"-16 x .312") .....	4	379746	Lockring .....	1
379746	Lockring .....	1	379688	Spline Lubricant.....	1
550311	Ball Bearing (1.770" x 3.346" x .748").....	1	550311	Ball Bearing (1.770" x 3.346" x .748").....	1
378263	Internal Lockring.....	1	378263	Internal Lockring.....	1
69-P-18	Tag Wet Spline .....	1			
			<b>329160-163X</b>	<b>Conversion Kit (XD to RZ WET) (281 Series)</b>	
<b>329160-160X</b>	<b>Conversion Kit (XD to RY DRY) (281 Series)</b>		3-P-1066	Output Shaft (1-1/4" - 14T).....	1
3-P-1067	Output Shaft (DIN 8T).....	1	28-P-285	O-ring (1.597" x .103").....	2
28-P-285	O-ring (1.597" x .103").....	2	379555	Lockring .....	2
379555	Lockring .....	2	380069	Lockring .....	1
380069	Lockring .....	1	21-P-934	Bearing Cap .....	1
21-P-933	Bearing Cap .....	1	28-P-267	Oil Seal (2.627" x 1.750" x .312").....	1
28-P-267	Oil Seal (2.627" x 1.750" x .312").....	1	21-P-731	Pump Flange.....	1
21-P-771	Pump Flange.....	1	329699-1X	Hose Assembly .....	1
28-P-329	O-ring (5.487" x .103").....	1	329700X	Wet Spline Parts Kit.....	1
328170-216X	Bag Kit .....	1	329658X	Cover Kit- XK, AF, AZ .....	1
380563-14	Hex Flange Head Cap Screw (.375"-16 x .312") .....	4	28-P-329	O-ring (5.487" x .103") .....	1
379746	Lockring .....	1	328170-216X	Bag Kit .....	1
379688	Spline Lubricant.....	1	380563-14	Hex Flange Head Cap Screw (.375"-16 x .312") .....	4
550311	Ball Bearing (1.770" x 3.346" x .748").....	1	379746	Lockring .....	1
378263	Internal Lockring.....	1	550311	Ball Bearing (1.770" x 3.346" x .748").....	1
			378263	Internal Lockring.....	1
			69-P-18	Wet Spline Tag .....	1

Continued on Next Page

BOMs in each kit group are listed in order based on part number.

**Kits Bill of Materials**

Part Number	Description	Qty.
<b>OUTPUT CONVERSION KITS (Continued)</b>		
<b>329160-164X</b>	<b>Conversion Kit (XD to RB DRY) (281/288 Series)</b>	
21-P-933	Bearing Cap .....	1
28-P-267	Oil Seal (2.627" x 1.750" x .312").....	1
21-P-894	Pump Flange.....	1
3-P-1126	Output Shaft (7/8" - 13T).....	1
28-P-285	O-ring (1.597" x .103").....	2
379555	Lockring .....	2
380069	Lockring .....	1
28-P-329	O-ring (5.487" x .103").....	1
328170-216X	Bag Kit .....	1
380563-14	Hex Flange Head Cap Screw (.375"-16 x .312").....	4
379746	Lockring .....	1
379688	Spline Lubricant.....	1
550311	Ball Bearing (1.770" x 3.346" x .748").....	1
378263	Lockring .....	1
<b>329160-165X</b>	<b>Conversion Kit (XD to RB WET) (281/288 Series)</b>	
21-P-894	Pump Flange.....	1
21-P-934	Bearing Cap .....	1
28-P-329	O-ring (5.487" x .103").....	1
28-P-267	Oil Seal (2.627" x 1.750" x .312").....	1
28-P-285	O-ring (1.597" x .103").....	2
328170-216X	Bag Kit .....	1
329658X	Cover Kit .....	1
378263	Lockring .....	1
379555	Lockring .....	2
379746	Lockring .....	1
380069	Lockring .....	1
380563-14	Hex Flange Head Cap Screw (.375"-16 x .312").....	4
3-P-1126	Output Shaft (7/8" - 13T).....	1
550311	Ball Bearing (1.770" x 3.346" x .748").....	1
329959X	Wet Spline Loose Parts Kit .....	1
329699-1X	Hose Assembly .....	1
69-P-18	Wet Spline Tag .....	1

BOMs in each kit group are listed in order based on part number.



**Offer of Sale**



**WARNING:** This product can expose you to chemicals including Lead and Lead Compounds, and Di(2-ethylhexyl)phthalate (DEHP) which are known to the State of California to cause cancer and birth defects or other reproductive harm. For more information go to [www.P65Warnings.ca.gov](http://www.P65Warnings.ca.gov)

**1. Definitions.** As used herein, the following terms have the meanings indicated.

**Buyer:** means any customer receiving a Quote for Products.

**Buyer's Property:** means any tools, patterns, plans, drawings, designs, specifications materials, equipment, or information furnished by Buyer, or which are or become Buyer's property.

**Confidential Information:** means any technical, commercial, or other proprietary information of Seller, including, without limitation, pricing, technical drawings or prints and/or part lists, which has been or will be disclosed, delivered, or made available, whether directly or indirectly, to Buyer.

**Goods:** means any tangible part, system or component to be supplied by Seller.

**Intellectual Property Rights:** means any patents, trademarks, copyrights, trade dress, trade secrets or similar rights.

**Products:** means the Goods, Services and/or Software as described in a Quote.

**Quote:** means the offer or proposal made by Seller to Buyer for the supply of Products.

**Seller:** means Parker-Hannifin Corporation, all divisions, subsidiaries and businesses selling products under these terms.

**Seller's IP:** means patents, trademarks, copyrights, or other intellectual property rights relating to the Products, including without limitation, names, designs, images, drawings, models, software, templates, information, any improvements or creations or other intellectual property developed prior to or during the relationship contemplated herein.

**Services:** means any services to be provided by Seller.

**Software:** means any software related to the Goods, whether embedded or separately downloaded.

**Special Tooling:** means equipment acquired by Seller or otherwise owned by Seller necessary to manufacture Goods, including but not limited to tools, jigs, and fixtures.

**Terms:** means the terms and conditions of this Offer of Sale.

**2. Terms.** All sales of Products by Seller will be governed by, and are expressly conditioned upon Buyer's assent to, these Terms. These Terms are incorporated into any Quote provided by Seller to Buyer. Buyer's order for any Products whether communicated to Seller verbally, in writing, by electronic data interface or other electronic commerce, shall constitute acceptance of these Terms. Seller objects to any contrary or additional terms or conditions of Buyer. Reference in Seller's order acknowledgement to Buyer's purchase order or purchase order number shall in no way constitute an acceptance of any of Buyer's terms or conditions of purchase. Any Quote made by Seller to Buyer shall be considered a firm and definite offer and shall not be deemed to be otherwise despite any language on the face of the Quote. Seller reserves all rights to accept or reject any purported acceptance by Buyer to Seller's Quote if such purported acceptance attempts to vary the terms of the Quote. If Seller ships Products after Buyer issues an acceptance to the Quote, any additional or different terms proposed by Buyer will not become part of the parties' business relationship unless agreed to in a writing that is signed by an authorized representative of Seller, excluding email correspondence. If the transaction proceeds without such agreement on the part of Seller, the business relationship will be

governed solely by these Terms and the specific terms in Seller's Quote.

**3. Price; Payment.** The Products set forth in the Quote are offered for sale at the prices indicated in the Quote. Unless otherwise specifically stated in the Quote, prices are valid for thirty (30) days and do not include any sales, use, or other taxes or duties. Seller reserves the right to modify prices for any reason and at any time by giving ten (10) days prior written notice. Unless otherwise specified by Seller, all prices are F.C.A. Seller's facility (INCOTERMS 2020). All sales are contingent upon credit approval and full payment for all purchases is due thirty (30) days from the date of invoice (or such date as may be specified in the Quote). Under any circumstances, Buyer may not withhold or suspend payment of any amounts due and payable as a deduction, set-off or recoupment of any amount, claim or dispute with Seller. Unpaid invoices beyond the specified payment date incur interest at the rate of 1.5% per month or the maximum allowable rate under applicable law. Seller reserves the right to require advance payment or provision of securities for first and subsequent deliveries if there is any doubt, in Seller's sole determination, regarding the Buyer's creditworthiness or for other business reasons. If the requested advance payment or securities are not provided to Seller's satisfaction, Seller reserves the right to suspend performance or reject the purchase order, in whole or in part, without prejudice to Seller's other rights or remedies, including the right to full compensation. Seller may revoke or shorten any payment periods previously granted in Seller's sole determination. The rights and remedies herein reserved to Seller are cumulative and in addition to any other or further rights and remedies available at law or in equity. No waiver by Seller of any breach by Buyer of any provision of these terms will constitute a waiver by Seller of any other breach of such provision.

**4. Shipment; Delivery; Title and Risk of Loss.** All delivery dates are approximate, and Seller is not responsible for damages or additional costs resulting from any delay. All deliveries are subject to our ability to procure materials from our suppliers. Regardless of the manner of shipment, delivery occurs and title and risk of loss or damage pass to Buyer, upon placement of the Products with the carrier at Seller's facility. Unless otherwise agreed prior to shipment and for domestic delivery locations only, Seller will select and arrange, at Buyer's sole expense, the carrier and means of delivery. When Seller selects and arranges the carrier and means of delivery, freight and insurance costs for shipment to the designated delivery location will be prepaid by Seller and added as a separate line item to the invoice. Buyer shall be responsible for any additional shipping charges incurred by Seller due to Buyer's acts or omissions. Buyer shall not return or repackage any Products without the prior written authorization from Seller, and any return shall be at the sole cost and expense of Buyer.

**5. Warranty.** The warranty for the Products is as follows: (i) Seller warrants that all products sold conform to the applicable Parker Chelsea standard specification for the lesser period of 2 years (24 Months) from date of service or 2-1/2 years (30 Months) from date of build (as marked on the product name plate; (ii) Services shall be performed in accordance with generally accepted practices and using the degree of care and skill that is ordinarily exercised and customary in the field to which the Services pertain and are warranted for a period of six (6) months from the date of completion of the Services; and (iii) Software is only warranted to perform in accordance with applicable specifications provided by Seller to Buyer for ninety (90) days from the date of delivery or, when downloaded by a Buyer or end-user, from the date of the initial download. All prices are based upon the exclusive limited warranty stated above, and upon the following disclaimer: **EXEMPTION CLAUSE; DISCLAIMER OF WARRANTY, CONDITIONS, REPRESENTATIONS: THIS WARRANTY IS THE SOLE AND ENTIRE WARRANTY, CONDITION, AND REPRESENTATION, PERTAINING TO PRODUCTS. SELLER**

Continued on Next Page



## Offer of Sale (Continued)

**DISCLAIMS ALL OTHER WARRANTIES, CONDITIONS, AND REPRESENTATIONS, WHETHER STATUTORY, EXPRESS OR IMPLIED, INCLUDING BUT NOT LIMITED TO THOSE RELATING TO DESIGN, NONINFRINGEMENT, MERCHANTABILITY, AND FITNESS FOR A PARTICULAR PURPOSE. SELLER DOES NOT WARRANT THAT THE SOFTWARE IS ERROR-FREE OR FAULT-TOLERANT, OR THAT BUYER'S USE THEREOF WILL BE SECURE OR UNINTERRUPTED, UNLESS OTHERWISE AUTHORIZED IN WRITING BY SELLER, THE SOFTWARE SHALL NOT BE USED IN CONNECTION WITH HAZARDOUS OR HIGH-RISK ACTIVITIES OR ENVIRONMENTS. EXCEPT AS EXPRESSLY STATED HEREIN, ALL PRODUCTS ARE PROVIDED "AS IS".**

**6. Claims; Commencement of Actions.** Buyer shall promptly inspect all Products upon receipt. No claims for shortages will be allowed unless reported to Seller within ten (10) days of delivery. Buyer shall notify Seller of any alleged breach of warranty within thirty (30) days after the date the non-conformance is or should have been discovered by Buyer. Any claim or action against Seller based upon breach of contract or any other theory, including tort, negligence, or otherwise must be commenced within twelve (12) months from the date of the alleged breach or other alleged event, without regard to the date of discovery.

**7. LIMITATION OF LIABILITY. IN THE EVENT OF A BREACH OF WARRANTY, SELLER WILL, AT ITS OPTION, REPAIR OR REPLACE THE NON-CONFORMING PRODUCTS, RE-PERFORM THE SERVICES, OR REFUND THE PURCHASE PRICE PAID WITHIN A REASONABLE PERIOD OF TIME. IN NO EVENT IS SELLER LIABLE FOR ANY SPECIAL, INDIRECT, INCIDENTAL OR CONSEQUENTIAL DAMAGES INCLUDING ANY LOSS OF REVENUE OR PROFITS, WHETHER BASED IN CONTRACT, TORT OR OTHER LEGAL THEORY. IN NO EVENT SHALL SELLER'S LIABILITY UNDER ANY CLAIM MADE BY BUYER EXCEED THE PURCHASE PRICE PAID FOR THE PRODUCTS.**

**8. Confidential Information.** Buyer acknowledges and agrees that Confidential Information has been and will be received in confidence and will remain the property of Seller. Buyer further agrees that it will not use Seller's Confidential Information for any purpose other than for the benefit of Seller and shall return all such Confidential Information to Seller within thirty (30) days upon request.

**9. Loss to Buyer's Property.** Buyer's Property will be considered obsolete and may be destroyed by Seller after two (2) consecutive years have elapsed without Buyer ordering the Products manufactured using Buyer's Property. Also, Seller shall not be responsible for any loss or damage to Buyer's Property while it is in Seller's possession or control.

**10. Special Tooling.** Seller may impose a tooling charge for any Special Tooling. Special Tooling shall be and remain Seller's property. In no event will Buyer acquire any interest in the Special Tooling, even if such Special Tooling has been specially converted or adapted for manufacture of Goods for Buyer and notwithstanding any charges paid by Buyer. Unless otherwise agreed, Seller has the right to alter, discard or otherwise dispose of any Special Tooling or other property owned by Seller in its sole determination at any time.

**11. Security Interest.** To secure payment of all sums due from Buyer, Seller retains a security interest in all Products delivered to Buyer and, Buyer's acceptance of these Terms is deemed to be a Security Agreement under the Uniform Commercial Code. Buyer authorizes Seller as its attorney to execute and file on Buyer's behalf all documents Seller deems necessary to perfect Seller's security interest.

**12. User Responsibility.** Buyer, through its own analysis and testing, is solely responsible for making the final selection of the Products and assuring that all performance, endurance, maintenance, safety and warning requirements of the application of the Products are met. Buyer must analyze all aspects of the application and follow applicable industry standards, specifications, and any technical information provided with the Quote or the Products, such as Seller's instructions, guides and specifications. If Seller provides options of or for Products based upon data

or specifications provided by Buyer, Buyer is responsible for determining that such data and specifications are suitable and sufficient for all applications and reasonably foreseeable uses of the Products. In the event Buyer is not the end-user of the Products, Buyer will ensure such end-user complies with this paragraph.

**13. Use of Products, Indemnity by Buyer.** Buyer shall comply with all instructions, guides and specifications provided by Seller with the Quote or the Products. If Buyer uses or resells the Products in any way prohibited by Seller's instructions, guides or specifications, or Buyer otherwise fails to comply with Seller's instructions, guides and specifications, Buyer acknowledges that any such use, resale, or non-compliance is at Buyer's sole risk. Further, Buyer shall indemnify, defend, and hold Seller harmless from any losses, claims, liabilities, damages, lawsuits, judgments and costs (including attorney fees and defense costs), whether for personal injury, property damage, intellectual property infringement or any other claim, arising out of or in connection with: (a) improper selection, design, specification, application, or any misuse of Products; (b) any act or omission, negligent or otherwise, of Buyer; (c) Seller's use of Buyer's Property; (d) damage to the Products from an external cause, repair or attempted repair by anyone other than Seller, failure to follow instructions, guides and specifications provided by Seller, use with goods not provided by Seller, or opening, modifying, deconstructing, tampering with or repackaging the Products; or (e) Buyer's failure to comply with these Terms, including any legal or administrative proceedings, collection efforts, or other actions arising from or relating to such failure to comply. Seller shall not indemnify Buyer under any circumstance except as otherwise provided in these Terms.

**14. Cancellations and Changes.** Buyer may not cancel or modify, including but not limited to movement of delivery dates for the Products, any order for any reason except with Seller's written consent and upon terms that will indemnify, defend and hold Seller harmless against all direct, incidental and consequential loss or damage and any additional expense. Seller, at any time, may change features, specifications, designs and availability of Products.

**15. Assignment.** Buyer may not assign its rights or obligations without the prior written consent of Seller.

**16. Force Majeure.** Seller is not liable for delay or failure to perform any of its obligations by reason of any events or circumstances beyond its reasonable control. Such circumstances include without limitation: accidents, labor disputes or stoppages, government acts or orders, acts of nature, pandemics, epidemics, other widespread illness, or public health emergency, cyber related disruptions, cyber-attacks, ransomware sabotage, delays or failures in delivery from carriers or suppliers, shortages of materials, sudden increases in the price of raw material or components, shutdowns or slowdowns affecting the supply of raw materials or components, or the transportation thereof, oil shortages or oil price increases, energy crisis, energy or fuel interruption, war (whether declared or not) or the serious threat of same, riots, rebellions, acts of terrorism, embargoes, fire or any reason whether similar to the foregoing or otherwise. Seller will resume performance as soon as practicable after the event of force majeure has been removed. All delivery dates affected by an event of force majeure shall be tolled for the duration of such event of force majeure and rescheduled for mutually agreed dates as soon as practicable after the event of force majeure ceases to exist. The right to allocate capacity is in the Seller's sole discretion. An event of force majeure shall not include financial distress, insolvency, bankruptcy, or other similar conditions affecting one of the parties, affiliates and/or subcontractors. An event of force majeure in the meaning of these Terms means any circumstances beyond Seller's control that permanently or temporarily hinders performance, even where that circumstance was already foreseen. Buyer shall not be entitled to cancel any orders following its claim of an event of force majeure.

**17. Waiver and Severability.** Failure to enforce any provision of these Terms will not invalidate that provision; nor will any such

Continued on Next Page



**Offer of Sale (Continued)**

**WARNING:** This product can expose you to chemicals including Lead and Lead Compounds, and Di(2-ethylhexyl)phthalate (DEHP) which are known to the State of California to cause cancer and birth defects or other reproductive harm. For more information go to [www.P65Warnings.ca.gov](http://www.P65Warnings.ca.gov)

failure prejudice either party's right to enforce that provision in the future. Invalidation of any provision of these Terms shall not invalidate any other provision herein and, the remaining provisions will remain in full force and effect.

**18. Duration.** Unless otherwise stated in the Quote, any agreement governed by or arising from these Terms shall: (a) be for an initial duration of one (1) year; and (b) shall automatically renew for successive one-year terms unless terminated by Buyer with at least 180-days written notice to Seller or if Seller terminates the agreement pursuant to Section 19 of these Terms.

**19. Termination.** Seller may, without liability to Buyer, terminate any agreement governed by or arising from these Terms for any reason and at any time by giving Buyer thirty (30) days prior written notice. Seller may immediately terminate, in writing, if Buyer: (a) breaches any provision of these Terms, (b) becomes or is deemed insolvent, (c) appoints or has appointed a trustee, receiver or custodian for all or any part of Buyer's property, (d) files a petition for relief in bankruptcy on its own behalf, or one is filed against Buyer by a third party, (e) makes an assignment for the benefit of creditors; or (f) dissolves its business or liquidates all or a majority of its assets.

**20. Ownership of Rights.** Buyer agrees that (a) Seller (and/or its affiliates) owns or is the valid licensee of Seller's IP and (b) the furnishing of information, related documents or other materials by Seller to Buyer does not grant or transfer any ownership interest or license in or to Seller's IP to Buyer, unless expressly agreed in writing. Without limiting the foregoing, Seller retains ownership of all Software supplied to Buyer. In no event shall Buyer obtain any greater right in and to the Software than a right in a license limited to the use thereof and subject to compliance with any other terms provided with the Software. Buyer further agrees that it will not, directly or through intermediaries, reverse engineer, decompile, or disassemble any Software (including firmware) comprising or contained within a Product, except and only to the extent that such activity may be expressly permitted, either by applicable law or, in the case of open-source software, the applicable open-source license.

**21. Indemnity for Infringement of Intellectual Property Rights.** Seller is not liable for infringement of any Intellectual Property Rights except as provided in this Section. Seller will defend at its expense and will pay the cost of any settlement or damages awarded in an action brought against Buyer based on a third-party claim that one or more of the Products infringes the Intellectual Property Rights of a third party in the country of delivery of the Products by Seller to Buyer. Seller's obligation to defend and indemnify Buyer is contingent on Buyer notifying Seller within ten (10) days after Buyer becomes aware of any such claim, and Seller having sole control over the defense of the claim including all negotiations for settlement or compromise. If one or more Products is subject to such a claim, Seller may, at its sole expense and option, procure for Buyer the right to continue using the Products, replace or modify the Products to render them non-infringing, or offer to accept return of the Products and refund the purchase price less a reasonable allowance for depreciation. Seller has no obligation or liability for any claim of infringement: (i) arising from information provided by Buyer (including Seller's use of Buyer's Property); or (ii) directed to any Products for which the designs are specified in whole or part by Buyer; or (iii) resulting from the modification, combination or use in a system of any Products. The foregoing provisions of this Section constitute Seller's sole and exclusive liability and Buyer's sole and exclusive remedy for claims of infringement of Intellectual Property Rights.

**22. Governing Law.** These Terms, the terms of any Quote, and the sale and delivery of all Products are deemed to have taken place in, and shall be governed and construed in accordance with, the laws of the State of Ohio, as applicable to contracts executed and wholly performed therein and without regard to conflicts of laws principles. Buyer irrevocably agrees and consents to the exclusive jurisdiction and venue of the courts of Cuyahoga County, Ohio with respect to any dispute, controversy or claim arising out of or relating to the sale

and delivery of the Products.

**23. Entire Agreement.** These Terms, along with the terms set forth in the Quote, forms the entire agreement between the Buyer and Seller and constitutes the final, complete and exclusive expression of the terms of sale and purchase. In the event of a conflict between any term set forth in the Quote and these Terms, the terms set forth in the Quote shall prevail. All prior or contemporaneous written or oral agreements or negotiations with respect to the subject matter shall have no effect. No modification to these Terms will be binding on Seller unless agreed to in a writing that is signed by an authorized representative of Seller, excluding email correspondence, 'clickwrap' or other purported electronic assent to different or additional terms. Sections 2-25 of these Terms shall survive termination or cancellation of any agreement governed by or arising from these Terms.

**24. No 'Wrap' Agreements/No Authority to Bind.** Seller's clicking any buttons or any similar action, such as clicking "I Agree" or "Confirm," to utilize Buyer's software or webpage for the placement of orders, is NOT an agreement to Buyer's Terms and Conditions. **NO EMPLOYEE, AGENT OR REPRESENTATIVE OF SELLER HAS THE AUTHORITY TO BIND SELLER BY THE ACT OF CLICKING ANY BUTTON OR SIMILAR ACTION ON BUYER'S WEBSITE OR PORTAL.**

**25. Compliance with Laws.** Buyer agrees to comply with all applicable laws, regulations, and industry and professional standards, including those of the United States of America, and the country or countries in which Buyer may operate, including without limitation the U.S. Foreign Corrupt Practices Act ("FCPA"), the U.S. Anti-Kickback Act ("Anti-Kickback Act"), U.S. and E.U. export control and sanctions laws ("Export Laws"), the U.S. Food Drug and Cosmetic Act ("FDCA"), and the rules and regulations promulgated by the U.S. Food and Drug Administration ("FDA"), each as currently amended. Buyer agrees to indemnify, defend, and hold harmless Seller from the consequences of any violation of such laws, regulations and standards by Buyer, its employees or agents. Buyer represents that it is familiar with all applicable provisions of the FCPA, the Anti-Kickback Act, Export Laws, the FDCA and the FDA and certifies that Buyer will adhere to the requirements thereof and not take any action that would make Seller violate such requirements. Buyer represents and agrees that Buyer will not make any payment or give anything of value, directly or indirectly, to any governmental official, foreign political party or official thereof, candidate for foreign political office, or commercial entity or person, for any improper purpose, including the purpose of influencing such person to purchase Products or otherwise benefit the business of Seller. Buyer further represents and agrees that it will not receive, use, service, transfer or ship any Products from Seller in a manner or for a purpose that violates Export Laws or would cause Seller to be in violation of Export Laws. Buyer agrees to promptly and reliably provide Seller all requested information or documents, including end-user statements and other written assurances, concerning Buyer's ongoing compliance with Export Law.

09/22



**Parker-Hannifin Corporation**

Chelsea Products Division  
8225 Hacks Cross Rd  
Olive Branch, MS 38654  
United States

Phone: +1 (662) 895-1011  
Email: [chd\\_support@support.parker.com](mailto:chd_support@support.parker.com)

[www.Parker.com/Chelsea](http://www.Parker.com/Chelsea)

PN: HY25-2281-M1/US  
Rev: 12/23